

Ruijie Reyee RG-NBS7003 Switch

Hardware Installation and Reference Guide

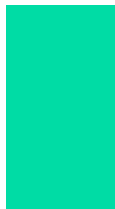
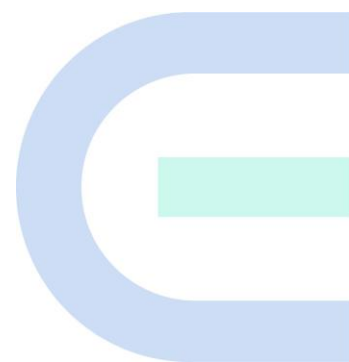

Copyright

Copyright © 2023 Ruijie Networks

All rights are reserved in this document and this statement.

Any reproduction, excerption, backup, modification, transmission, translation or commercial use of this document or any portion of this document, in any form or by any means, without the prior written consent of Ruijie Networks is prohibited.

Trademarks including ,  are owned by Ruijie Networks.

All other trademarks or registered trademarks mentioned in this document are owned by their respective owners.

Disclaimer

The products, services, or features you purchase are subject to commercial contracts and terms. Some or all of the products, services or features described in this document may not be within the scope of your purchase or use. Unless otherwise agreed in the contract, Ruijie Networks does not make any express or implied statement or guarantee for the content of this document.

Due to product version upgrades or other reasons, the content of this document will be updated from time to time. Ruijie Networks reserves the right to modify the content of the document without any notice or prompt.

This manual is for reference only. Ruijie Networks endeavors to ensure content accuracy and will not shoulder any responsibility for losses and damages caused due to content omissions, inaccuracies or errors.

Preface

Intended Audience

This document is intended for:

- Network engineers
- Technical support and service engineers
- Network administrators

Technical Support

- Official website of Ruijie Reye: <https://www.ruijienetworks.com/products/reeye>
- Technical support website: <https://ruijienetworks.com/support>
- Case portal: <https://caseportal.ruijienetworks.com>
- Community: <https://community.ruijienetworks.com>
- Technical support email: service_rj@ruijienetworks.com

Conventions

1. GUI Symbols

Interface symbol	Description	Example
Boldface	1. Button names 2. Window names, tab name, field name and menu items 3. Link	1. Click OK . 2. Select Config Wizard . 3. Click the Download File link.
>	Multi-level menu items	Choose System > Time .

2. Signs

The signs used in this document are described as follows:

Warning

An alert that calls attention to important rules and information that if not understood or followed can result in data loss or equipment damage.

Caution

An alert that calls attention to essential information that if not understood or followed can result in function failure or performance degradation.

 Note

An alert that contains additional or supplementary information that if not understood or followed will not lead to serious consequences.

 Specification

An alert that contains a description of product or version support.

3. Note

This manual provides the device installation steps, hardware troubleshooting, module technical specifications, and specifications and usage guidelines for cables and connectors. It is intended for the users who have some experience in installing and maintaining network hardware. At the same time, it is assumed that the users are already familiar with the related terms and concepts.

1 Product Overview

The RG-NBS7000 series switches are next-generation switches launched by Ruijie independently. The switch comes into two models: RG-NBS7003 and RG-NBS7006.

- RG-NBS7003: Any line card can work as a supervisor engine in slot 1 (slot 1 must be occupied). The switch provides three line card slots.

1.1 RG-NBS7003 Switch

1.1.1 Package Contents

Table 1-1 Package Contents

Item	Quantity
Chassis	1
M7003-FAN Module	1
Cable management brackets	6
M3 x 10 mm screw	8
M6 x 16 mm screw	12
M6 cage nuts	12
Anti-static wrist strap	1
Yellow/green grounding cable	1
Warranty Card	1
User Manual	1
Mounting bracket	2 (pre-installed)
Product management software of Ruijie Networks	1 (pre-installed)

Instruction

- The preceding table lists items delivered in normal cases. The actually delivered items may vary with the contract. Carefully check your goods against the package contents or contract. Contact the seller if you have any questions or find any errors.

1.1.2 Product Appearance

The hardware system of the RG-NBS7003 switch includes the chassis, power supply system, system modules and heat dissipation system.

- The power supply system: The switch provides two power supply slots and supports 1+1 power redundancy.

You are advised to configure power supply redundancy.

- System modules: The switch provides three line card slots. Any line card can work as a supervisor engine in slot 1. You can select different line cards as needed. Slot 1 must be occupied.
- The heat dissipation system: The heat dissipation system consists of fan modules in the rear of the chassis.

Figure 1-1 Appearance of the RG-NBS7003 Switch

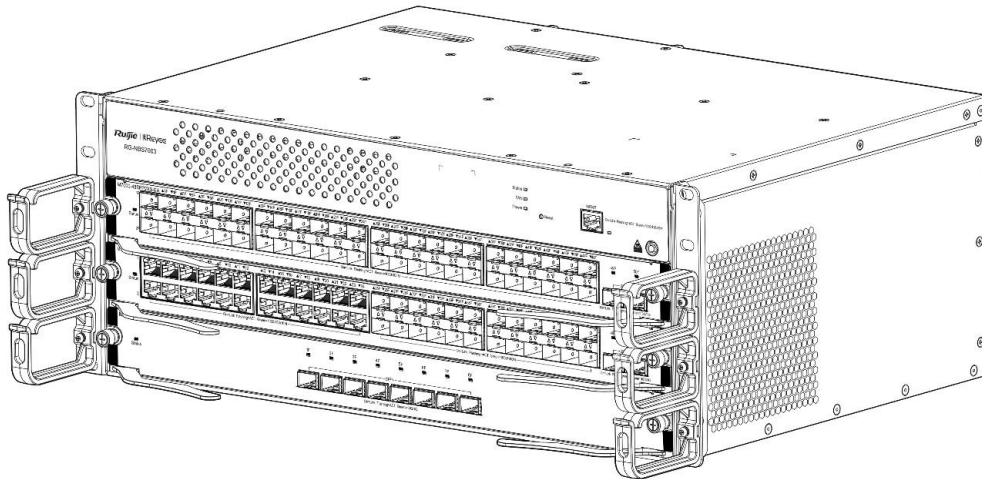

1.1.3 Ports - Front Panel

The front panel of the RG-NBS7003 switch is shown in Figure 1-2.

Figure 1-2 Front Panel of the RG-NBS7003 Switch

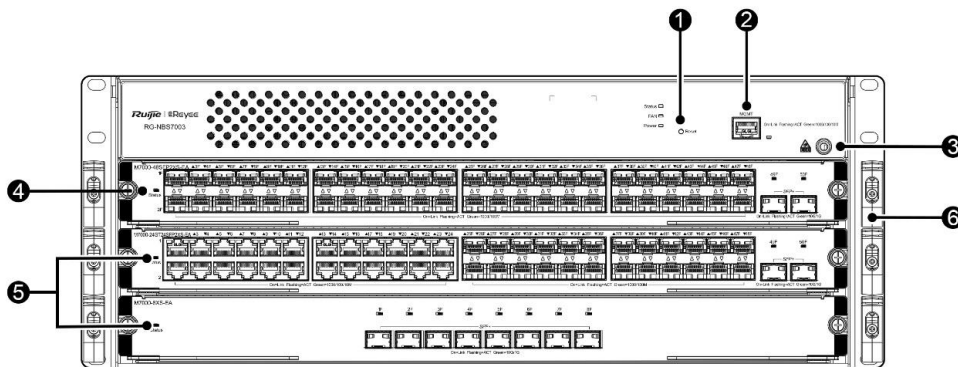

1. Reset Button	4. Slot 1 (Supervisor Engine)
2. Management Port	5. Slot 2 and Slot 3 (Line Card)
3. Anti-Static Wrist Strap Socket	6. Cable Management Frame

⚠ Caution

Ensure the line cards and power supply modules are removed from the chassis before you move the RG-NBS7003 chassis.

- Press the Reset button for no more than two seconds , and all modules will be reset.
- Press the Reset button for two to five seconds , and no configurations will be changed and no module will be reset.
- Press the Reset button for over 5 seconds, and all modules will be restored to factory settings with configuration backup saved. After restart, use the default password to log in to the Web management system. You can select Reset Backup to restore previous configurations, or select Delete Backup to delete previous configurations.

1.1.4 Ports - Rear Panel

The Rear panel of the RG-NBS7003 switch is shown in Figure 1-3.

Figure 1-3 Back Panel of the RG-NBS7003 Switch

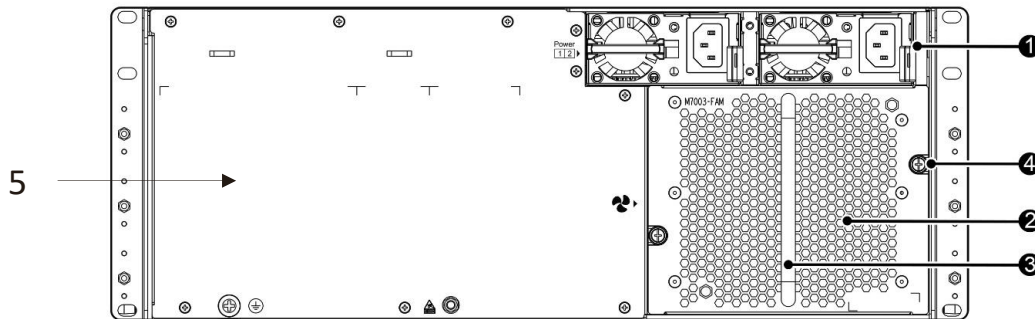

1. Power Supply Module	4. Captive Screw
2. Fan Module	5. Nameplate
3. Fan Module Handle	

1.1.5 Power Supply

The RG-NBS7003 switch adopts AC power input.

- The RG-PA300I-FS and RG-PA460I-FS modules are available. If you want to use three M7000-48SFP2XS-EA modules, a combination of two M7000-48SFP2XS-EA modules and one M7000-24GT24SFP2XS-EA module, a combination of two M7000-48SFP2XS-EA modules and one M7000-16XS-EA, or a combination of one M7000-48SFP2XS-EA module and two M7000-16XS-EA modules, select the RG-PA460I-FS module. In other cases, select the RG-PA300I-FS module.

Note

The RG-NBS7003 switch supports 1+1 power supply redundancy. You are advised to configure power supply redundancy to improve system stability and reliability.

1.1.6 LEDs

LED	Panel Identification	Status	Meaning
System Status LED	Status	Off	The switch is powered off.
		Blinking green (Fast)	The switch is being initialized.
		Blinking green (Slow)	The switch has been initialized and has not accessed Ruijie Cloud.
		Solid green	The switch has been initialized and accessed Ruijie Cloud.
		Solid yellow	Possible cases: 1. A temperature alarm is generated. 2. A fan module is not in place. 3. The supervisor engine is not functioning properly.
Solid red	The system is not functioning properly due to a fan fault, power fault, or system fault. The switch may be damaged if it continues to work.		
MGMT Port Status LED	Link/ACT	Off	No link is detected for this port.
		Solid green	The port has made a successful 10/100/1000 Mbps link.
		Blinking	The port is transmitting or receiving data.
Fan Status LED	FAN	Off	The switch is powered off or the initialization process is not complete.
		Solid green	The fan module is operating normally.
		Solid yellow	The fan module is not in place.
		Solid red	The fan module is not functioning properly.
Power Supply Status LED	Power	Off	The switch is powered off or the initialization process is not complete.
		Solid green	The power supply module is operating normally.
		Solid red	The power supply module is not functioning properly.

1.1.7 Heat Dissipation

The working temperature of the RG-NBS7003 switch ranges from 0 to 50°C (32°F to 122°F). The heat dissipation design needs to ensure the stability, safety and maintainability of the switch in such environment. The RG-NBS7003 switch adopts fan ventilation and forced convection to ensure the switch can work normally in specified environment.

Figure 1-4 Air Intake Design

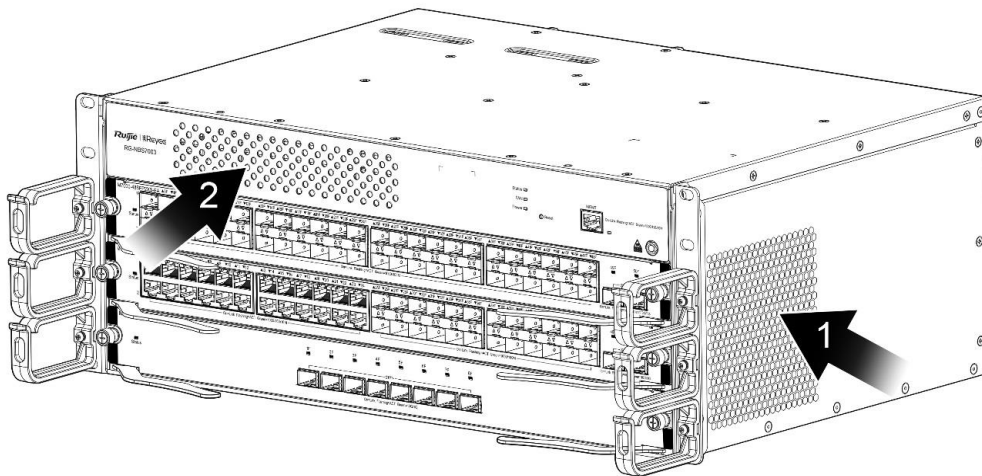

- | | |
|----------------------------------------------------------------------------------------------------------------|-----------------------------------------|
| 1. Air intakes for line cards and the supervisor engine (line card in slot 1 working as the supervisor engine) | 2. Air intakes for power supply modules |
|----------------------------------------------------------------------------------------------------------------|-----------------------------------------|

Figure 1-5 Air Exhaust Design

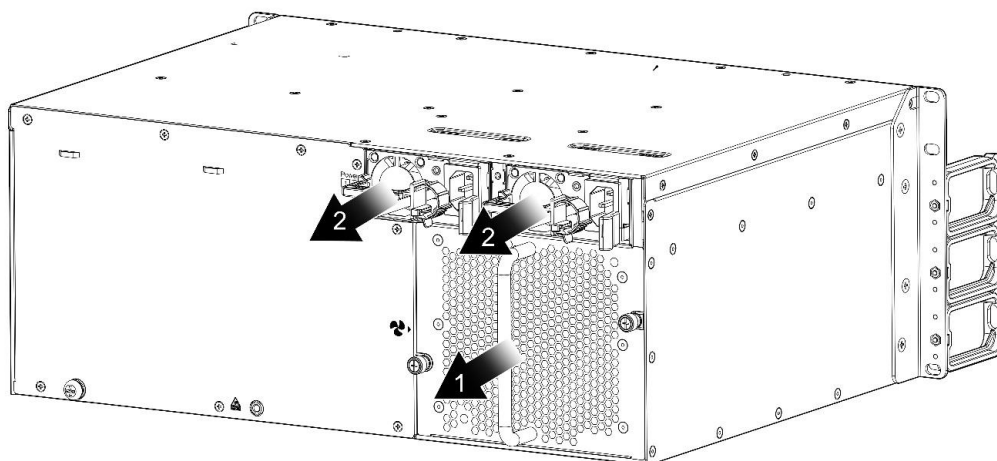

1. Air exhaust for line cards and the supervisor engine (line card in slot 1 working as the supervisor engine)

2. Air exhaust for power supply modules

The line cards and the supervisor engine adopts right-to-rear airflow for proper ventilation.

The power supply module adopts front-to-rear airflow for proper ventilation.

 Note

Maintain a minimum clearance of 10 cm (3.94 in.) around the chassis to allow air circulation. Install a filler panel properly in an empty slot for ventilation.

1.1.8 Technical Specifications

Model	RG-NBS7003
Module Slot	Three line card slots
Supervisor Engine	Any line card can work as a supervisor engine in slot 1 (slot 1 must be occupied).
Supervisor Engine Redundancy	Not supported
Line Card	The following seven line card models are available: M7000-48GT2XS-EA M7000-24GT2XS-EA M7000-24GT24SFP2XS-EA M7000-48SFP2XS-EA M7000-24SFP2XS-EA M7000-8XS-EA M7000-16XS-EA
Hot Swapping	Fan modules and power supply modules support hot swapping. Line cards do not support hot swapping.
Power Supply Module	RG-PA300I-FS: 100 V AC to 240 V AC Power: 300 W RG-PA460I-FS: 100 V AC to 240 V AC Power: 460 W
Power Supply Redundancy	Supported (same model)
Fan Module	M7003-FAN
Certificate	CE
Altitude	Long term operation height: 3000 m at 50°C (122°F). At a height between 3000 m (9842.52 ft) and 5000 m (16404.2 ft), every time the altitude increases by 220 m (721.79 ft), the maximum temperature decreases by 1°C (1.8°F).
	Operating height: up to 5000 m (16404.2 ft)
	Storage height: up to 5000 m (16404.2 ft)
Operating Temperature	0°C to 50°C (32°F to 122°F)
Storage Temperature	-40°C to +70°C (-40°F to +158°F)
Operating Humidity	10% to 90% RH (non-condensing)

MTBF	Over 200,000 hours
Noise	50 dB at 35°C (95°F) 60 dB at 50°C (122°F)
Weight	Net weight: 9.6 kg (21.16 lbs)
Dimensions (W x D x H)	442 mm x 313 mm x 175 mm (17.40 in. x 12.32 in. x 6.89 in., without cable management brackets), 4 RU

Note

The weight only includes that of the empty chassis and fans. The weight of the whole device is subject to the modules selected.

Caution

Operation of this equipment in a residential environment could cause radio interference. This equipment is not suitable for use in locations where children are likely to be present.

2 Modules

The RG-NBS7003 switch adopts a modular design. Compliant with industry standards, the design divides system modules and integrates module interfaces to ensure system perfection and module independence. On the RG-NBS7003, any line card can work as a supervisor engine in slot 1. The line cards provide 10/100/1000 Mbps Ethernet electrical ports with auto-negotiation, 100/1000 Mbps SFP (SMF/MMF) ports, and 10GE SFP+ ports.

2.1 Line Cards

Any line card in slot 1 works as the supervisor engine.

2.1.1 M7000-16XS-EA

Module Appearance

Figure 2-1 Appearance of the M7000-16XS-EA Module

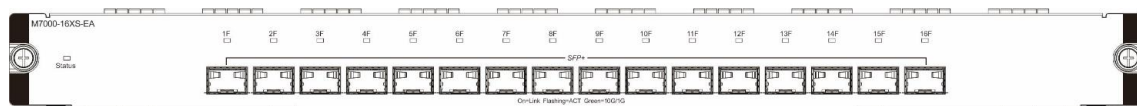

Ports

The M7000-16XS-EA module provides 16 x SFP+ ports. The SFP+ port supports 10GE SFP+ modules, 1GE SFP modules, and hot swapping.

LEDs

LED	Panel Identification	Status	Meaning
System LED	Status	Off	The module is powered off.
		Blinking green	The module is being initialized. Continuous blinking indicates a fault.
		Solid green	Initialization is complete.
SFP+ Port LED	1F to 16F	Off	No link is detected for this port.
		Solid green	The port has made a successful link.
		Blinking green	The port is transmitting or receiving data.

Specifications

Model	M7000-16XS-EA
CPU	1.0 GHz dual-core CPU
BOOTROM	N/A
Flash Memory	256 MB
SDRAM	DDRIII 1 GB
Ports	16 x SFP+ ports
SFP Modules and Cables	For details, see Appendix B. (Copper cables are not supported.) The supported models may be subject to change without prior notice. Contact Ruijie Networks for details.
LED	Status LED Link/ACT LED
Hot Swapping	Not supported
Power Consumption	< 82 W
Certificate	CE
Operating	0°C to 50°C (32°F to 122°F)

Temperature	
Storage Temperature	-40°C to +70°C (-40°F to +158°F)
Operating Humidity	10% to 90% RH (non-condensing)
MTBF	Over 200,000 hours
Weight	Net weight: 1.75 kg (3.86 lbs)
Dimensions (W x D x H)	438.5 mm x 196 mm x 40.2 mm (17.26 in. x 7.72 in. x 1.58 in.)

2.1.2 M7000-24GT24SFP2XS-EA

Module Appearance

Figure 2-2 Appearance of the M7000-24GT24SFP2XS-EA Module

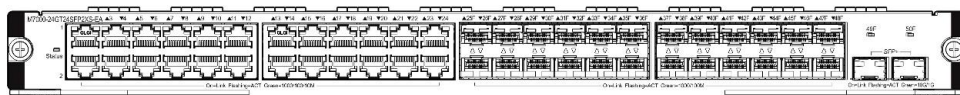

Ports

The M7000-24GT24SFP2XS-EA module provides 24 x 10/100/1000BASE-T RJ45 ports, 24 x SFP ports, and 2 x SFP+ ports. The RJ45 port supports 10/100/1000 Mbps auto-negotiation. The SFP port supports the 100/1000 Mbps auto-negotiation and hot swapping. The SFP+ port supports 10GE SFP+ modules, 1GE SFP modules, and hot swapping.

LEDs

LED	Panel Identification	Status	Meaning
System LED	Status	Off	The module is powered off.
		Blinking green	The module is being initialized. Continuous blinking indicates a fault.
		Solid green	Initialization is complete.
RJ45 Port LED	1F to 24F	Off	No link is detected for this port.
		Solid green	The port has made a successful 10/100/1000 Mbps link.

		Blinking green	The port is transmitting or receiving data at 10/100/1000 Mbps.
SFP Port LED	25F to 48F	Off	No link is detected for this port.
		Solid green	The port has made a successful link.
		Blinking green	The port is transmitting or receiving data.
SFP+ Port LED	49F to 50F	Off	No link is detected for this port.
		Solid green	The port has made a successful link.
		Blinking green	The port is transmitting or receiving data.

Specifications

Model	M7000-24GT24SFP2XS-EA
CPU	1.0 GHz dual-core CPU
BOOTROM	N/A
Flash Memory	256 MB
SDRAM	DDRIII 1 GB
Ports	24 x 10/100/1000BASE-T RJ45 ports 24 x SFP ports 2 x SFP+ ports
SFP Modules and Cables	For details, see Appendix B. (Copper cables are not supported.) The supported models may be subject to change without prior notice. Contact Ruijie Networks for details.
LED	Status LED Link/ACT LED
Hot Swapping	Not supported
Power Consumption	< 75 W

Certificate	CE
Operating Temperature	0°C to 50°C (32°F to 122°F)
Storage Temperature	-40°C to +70°C (-40°F to +158°F)
Operating Humidity	10% to 90% RH (non-condensing)
MTBF	Over 200,000 hours
Weight	Net weight: 2.1 kg (4.63 lbs)
Dimensions (W x D x H)	438.5 mm x 196 mm x 40.2 mm (17.26 in. x 7.72 in. x 1.58 in.)

2.1.3 M7000-48GT2XS-EA

Module Appearance

Figure 2-3 Appearance of the M7000-48GT2XS-EA Module

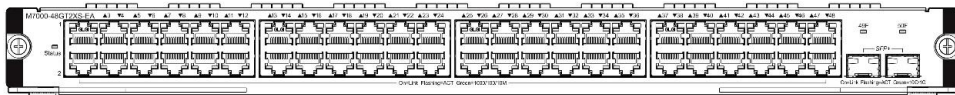

Ports

The M7000-48GT2XS-EA module provides 48 x 10/100/1000BASE-T RJ45 ports and 2 x SFP+ ports. The RJ45 port supports 10/100/1000 Mbps auto-negotiation. The SFP+ port supports 10GE SFP+ modules, 1GE SFP modules, and hotswapping.

LEDs

LED	Panel Identification	Status	Meaning
System LED	Status	Off	The module is powered off.
		Blinking green	The module is being initialized. Continuous blinking indicates a fault.
		Solid green	Initialization is complete.
RJ45 Port LED	1F to 48F	Off	No link is detected for this port.

		Solid green	The port has made a successful 10/100/1000 Mbps link.
		Blinking green	The port is transmitting or receiving data at 10/100/1000 Mbps.
SFP+ Port LED	49F to 50F	Off	No link is detected for this port.
		Solid green	The port has made a successful link.
		Blinking green	The port is transmitting or receiving data.

Specifications

Model	M7000-48GT2XS-EA
CPU	1.0 GHz dual-core CPU
BOOTROM	N/A
Flash Memory	256 MB
SDRAM	DDRIII 1 GB
Ports	48 x 10/100/1000BASE-T RJ45 ports 2 x SFP+ ports
SFP Modules and Cables	For details, see Appendix B. (Copper cables are not supported.) The supported models may be subject to change without prior notice. Contact Ruijie Networks for details.
LED	Status LED Link/ACT LED
Hot Swapping	Not supported
Power Consumption	< 54W
Certificate	CE
Operating Temperature	0°C to 50°C (32°F to 122°F)
Storage	-40°C to +70°C (-40°F to +158°F)

Temperature	
Operating Humidity	10% to 90% RH (non-condensing)
MTBF	Over 200,000 hours
Weight	Net weight: 2.05 kg (4.52 lbs)
Dimensions (W x D x H)	438.5 mm x 196 mm x 40.2 mm (17.26 in. x 7.72 in. x 1.58 in.)

2.1.4 M7000-24GT2XS-EA

Module Appearance

Figure 2-4 Appearance of the M7000-24GT2XS-EA Module

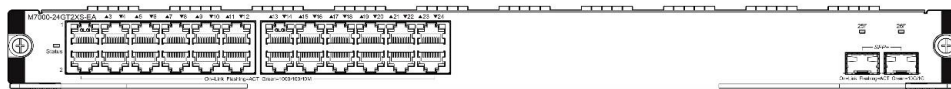

Ports

The M7000-24GT2XS-EA module provides 24 x 10/100/1000BASE-T RJ45 ports and 2 x SFP+ ports. The RJ45 port supports 10/100/1000 Mbps auto-negotiation. The SFP+ port supports 10GE SFP+ modules, 1GE SFP modules, and hot swapping.

LEDs

LED	Panel Identification	Status	Meaning
System LED	Status	Off	The module is powered off.
		Blinking green	The module is being initialized. Continuous blinking indicates a fault.
		Solid green	Initialization is complete.
RJ45 Port LED	1F to 24F	Off	No link is detected for this port.
		Solid green	The port has made a successful 10/100/1000 Mbps link.
		Blinking green	The port is transmitting or receiving data at 10/100/1000 Mbps.

SFP+ Port LED	25F to 26F	Off	No link is detected for this port.
		Solid green	The port has made a successful link.
		Blinking green	The port is transmitting or receiving data.

Specifications

Model	M7000-24GT2XS-EA
CPU	1.0 GHz dual-core CPU
BOOTROM	N/A
Flash Memory	256 MB
SDRAM	DDRIII 1 GB
Ports	24 x 10/100/1000BASE-T RJ45 ports 2 x SFP+ ports
SFP Modules and Cables	For details, see Appendix B. (Copper cables are not supported.) The supported models maybe subject to change without prior notice. Contact Ruijie Networks for details.
LED	Status LED Link/ACT LED
Hot Swapping	Not supported
Power Consumption	< 41W
Certificate	CE
Operating Temperature	0°C to 50°C (32°F to 122°F)
Storage Temperature	-40°C to +70°C (-40°F to +158°F)
Operating Humidity	10% to 90% RH (non-condensing)
MTBF	Over 200,000 hours

Weight	Net weight: 2.00 kg (4.41 lbs)
Dimensions (W x D x H)	438.5 mm x 196 mm x 40.2 mm (17.26 in. x 7.72 in. x 1.58 in.)

2.1.5 M7000-48SFP2XS-EA

Module Appearance

Figure 2-5 Appearance of the M7000-48SFP2XS-EA Module

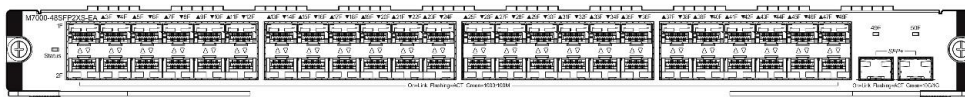

Ports

The M7000-48SFP2XS-EA module provides 48 x SFP ports and 2 x SFP+ ports. The SFP port supports the 100/1000 Mbps auto-negotiation and hot swapping. The SFP+ port supports 10GE SFP+ modules, 1GE SFP modules, and hot swapping.

LEDs

LED	Panel Identification	Status	Meaning
System LED	Status	Off	The module is powered off.
		Blinking green	The module is being initialized. Continuous blinking indicates a fault.
		Solid green	Initialization is complete.
SFP Port LED	1F to 48F	Off	No link is detected for this port.
		Solid green	The port has made a successful link.
		Blinking green	The port is transmitting or receiving data.
SFP+ Port LED	49F to 50F	Off	No link is detected for this port.
		Solid green	The port has made a successful link.
		Blinking green	The port is transmitting or receiving data.

Specifications

Model	M7000-48SFP2XS-EA
CPU	1.0 GHz dual-core CPU
BOOTROM	N/A
Flash Memory	256 MB
SDRAM	DDRIII 1 GB
Ports	48 x SFP ports 2 x SFP+ ports
SFP Modules and Cables	For details, see Appendix B. (Copper cables are not supported.) The supported models maybe subject to change without prior notice. Contact Ruijie Networks for details.
LED	Status LED Link/ACT LED
Hot Swapping	Not supported
Power Consumption	< 97W
Certificate	CE
Operating Temperature	0°C to 50°C (32°F to 122°F)
Storage Temperature	-40°C to +70°C (-40°F to +158°F)
Operating Humidity	10% to 90% RH (non-condensing)
MTBF	Over 200,000 hours
Weight	Net weight: 2.15 kg (4.74 lbs)
Dimensions (W x D x H)	438.5 mm x 196 mm x 40.2 mm (17.26 in. x 7.72 in. x 1.58 in.)

2.1.6 M7000-24SFP2XS-EA

Module Appearance

Figure 2-6 Appearance of the M7000-24SFP2XS-EA Module

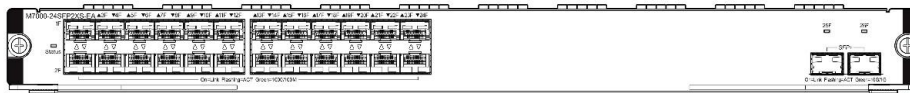

Ports

The M7000-24SFP2XS-EA module provides 24 x SFP ports and 2 x SFP+ ports. The SFP port supports the 100/1000 Mbps auto-negotiation and hot swapping. The SFP+ port supports 10GE SFP+ modules, 1GE SFP modules, and hot swapping.

LEDs

LED	Panel Identification	Status	Meaning
System LED	Status	Off	The module is powered off.
		Blinking green	The module is being initialized. Continuous blinking indicates a fault.
		Solid green	Initialization is complete.
SFP Port LED	1F to 24F	Off	No link is detected for this port.
		Solid green	The port has made a successful link.
		Blinking green	The port is transmitting or receiving data.
SFP+ Port LED	25F to 26F	Off	No link is detected for this port.
		Solid green	The port has made a successful link.
		Blinking green	The port is transmitting or receiving data.

Specifications

Model	M7000-24SFP2XS-EA
CPU	1.0 GHz dual-core CPU
BOOTROM	N/A
Flash Memory	256 MB

SDRAM	DDRIII 1 GB
Ports	24 x SFP ports 2 x SFP+ ports
SFP Modules and Cables	For details, see Appendix B. (Copper cables are not supported.) The supported models maybe subject to change without prior notice. Contact Ruijie Networks for details.
LED	Status LED Link/ACT LED
Hot Swapping	Not supported
Power Consumption	< 58W
Certificate	CE
Operating Temperature	0°C to 50°C (32°F to 122°F)
Storage Temperature	-40°C to +70°C (-40°F to +158°F)
Operating Humidity	10% to 90% RH (non-condensing)
MTBF	Over 200,000 hours
Weight	Net weight: 2.00 kg (4.41 lbs)
Dimensions (W x D x H)	438.5 mm x 196 mm x 40.2 mm (17.26 in. x 7.72 in. x 1.58 in.)

2.1.7 M7000-8XS-EA

Module Appearance

Figure 2-7 Appearance of the M7000-8XS-EA Module

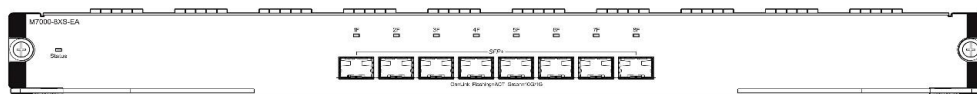

Ports

The M7000-8XS-EA module provides 8 x SFP+ ports. The SFP+ port supports 10GE SFP+ modules, 1GE SFP modules, and hot swapping.

LEDs

LED	Panel Identification	Status	Meaning
System LED	Status	Off	The module is powered off.
		Blinking green	The module is being initialized. Continuous blinking indicates a fault.
		Solid green	Initialization is complete.
SFP+ Port LED	1F to 8F	Off	No link is detected for this port.
		Solid green	The port has made a successful link.
		Blinking green	The port is transmitting or receiving data.

Specifications

Model	M7000-8XS-EA
CPU	1.0 GHz dual-core CPU
BOOTROM	N/A
Flash Memory	256 MB
SDRAM	DDRIII 1 GB
Ports	8 x SFP+ ports
SFP Modules and Cables	For details, see Appendix B. (Copper cables are not supported.) The supported models maybe subject to change without prior notice. Contact Ruijie Networks for details.
LED	Status LED Link/ACT LED
Hot Swapping	Not supported
Power	< 43W

Consumption	
Certificate	CE
Operating Temperature	0°C to 50°C (32°F to 122°F)
Storage Temperature	-40°C to +70°C (-40°F to +158°F)
Operating Humidity	10% to 90% RH (non-condensing)
MTBF	Over 200,000 hours
Weight	Net weight: 1.75 kg (3.86 lbs)
Dimension (W x D x H)	438.5 mm x 196 mm x 40.2 mm (17.26 in. x 7.72 in. x 1.58 in.)

2.2 Power Supply Modules

2.2.1 RG-PA300I-FS

Module Appearance

Figure 2-8 Appearance of the RG-PA300I-FS Module

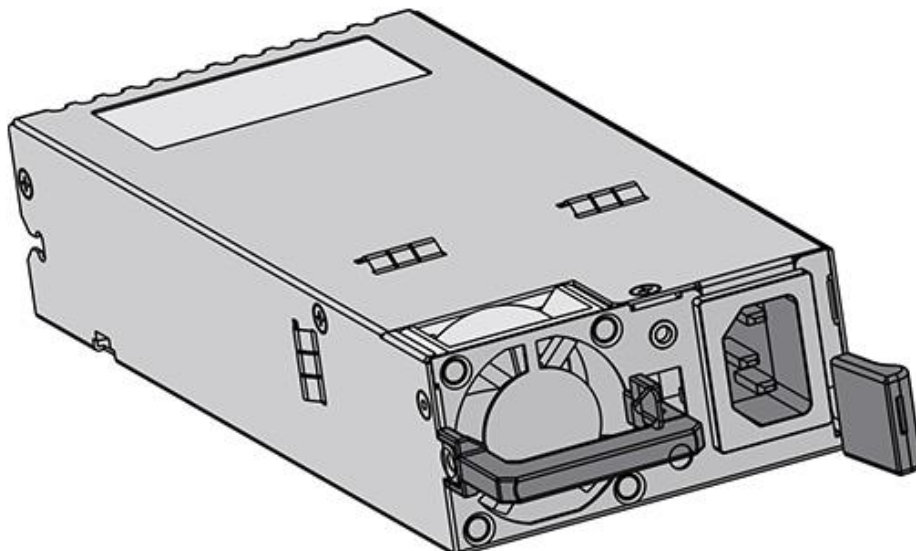

Ports

The RG-PA300I-FS module provides 12 V AC input to the RG-NBS7003 switch. The front panel of the power supply module provides a 3-pin connector, which can be connected to a standard 10 A power cord.

LED

LED	Indicator	Status	Meaning
Status LED	N/A	Off	A power fault occurs or there is no power input.
		Solid green	The module is operating normally.

Specifications

Module Model	RG-PA300I-FS
Rated Voltage Range	100 V AC to 120 V AC, 200 V AC to 240 V AC; 50 Hz to 60 Hz
Max Voltage Range	90 V AC to 264 V AC; 47 Hz to 63 Hz
Max Power Output	100 V AC to 240 V AC; Power: 300 W
Input Leakage Current	≤ 1.5 mA
Weight	Net weight: 0.85 kg (1.87 lbs)
Power Cord Requirement	10 A power cord

⚠ Caution

- When you plug in a power cord, press the cable retention clip toward the plug to secure the cord.
- Connect a power cord to an output socket connected to the ground.
- The maximum operation altitude and storage altitude are both 5000 m (16404.2 ft).

2.2.2 RG-PA460I-FS**Module Appearance**

Figure 2-9 Appearance of the RG-PA460I-FS Module

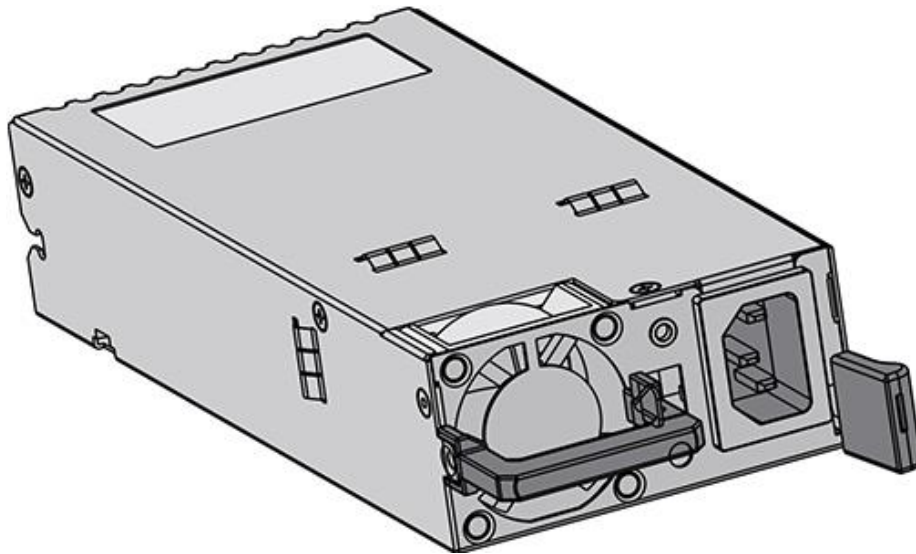

Ports

The RG-PA460I-FS module provides 12 V AC input to the RG-NBS7003 switch. The front panel of the power supply module provides a 3-pin connector, which can be connected to a standard 10 A power cord.

LED

LED	Indicator	Status	Meaning
Status LED	N/A	Off	A power fault occurs or there is no power input.
		Solid green	The module is operating normally.

Specifications

Module Model	RG-PA460I-FS
Rated Voltage Range	100 V AC to 120 V AC, 200 V AC to 240 V AC; 50 Hz to 60 Hz
Max Voltage Range	90 V AC to 264 V AC; 47 Hz to 63 Hz
Max Power Output	100 V AC to 240 V AC; Power: 460 W
Input Leakage Current	≤ 3 mA
Weight	Net weight: 0.9 kg (1.98 lbs)
Power Cord Requirement	10 A power cord

⚠ Caution

- When you plug in a power cord, press the retention clip toward the plug to secure the cord.
- Connect a power cord to an output socket connected to the ground.
- The max operation altitude and storage altitude are both 5000 m (16404.2 ft).

2.3 Fan Modules

2.3.1 M7003-FAN

Module Appearance

Figure 2-10 Appearance of the M7003-FAN Module

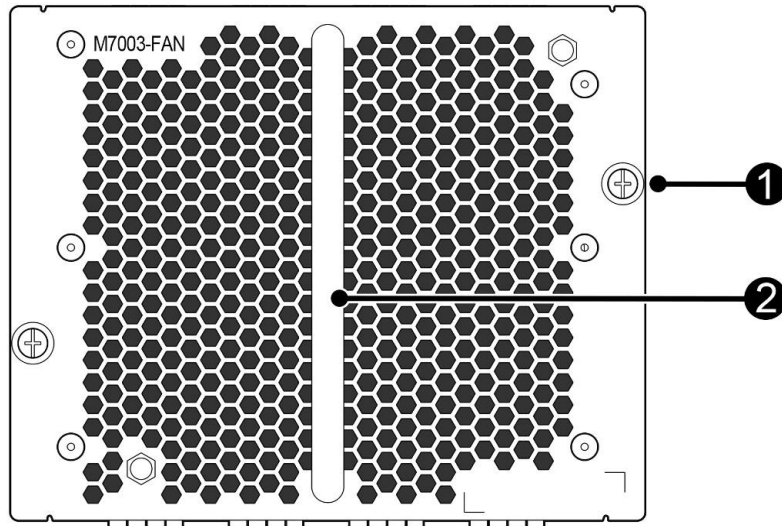

1. Captive Screw	2. Handle
------------------	-----------

Composition

The M7003-FAN is the fan module of the RG-NBS7003 switch. Each fan module consists of a fan and a fan monitoring board.

Specifications

Dimension (W x D x H)	167.5 mm x 132 mm x 133 mm (6.59 in. x 5.20 in. x 5.24 in.)
---------------------------------	-------------------------------------------------------------

Features

Function	Meaning
----------	---------

Status Monitoring	Rotation speed monitoring and failure alarm
Automatic Speed Adjustment	Automatic speed adjustment based on temperature
Hot Swapping	The fan tray supports hotswapping. For operation details, see Hardware Maintenance.

3 Preparation before Installation

3.1 Safety Suggestions

 Caution

- To avoid body injury and equipment damage, carefully read the safety suggestions before you install the RG-NBS7000 series switches.
 - The following safety suggestions do not cover all possible dangers.
-

3.1.1 General Safety Precautions

- Take security measures (such as wearing an anti-static wrist strap) to ensure safety.
- Keep the chassis clean and dust-free. Do not place the switch at a damp place and keep the switch away from moisture.
- Make sure the installation site is dry and flat. Take skid-proof measures.
- Do not place the switch in a walking area.
- Do not wear loose clothes or any other things that may be caught by the chassis during installation and maintenance.
- Moving or lifting the switch and its components requires team work. Be careful not to get hurt.

3.1.2 Handling Safety

The switches are large and heavy. When you handle the switches, pay attention to the following requirements:

- Avoid moving the equipment frequently.
- Turn off all power supplies and unplug all power cables before you remove the equipment.
- At least four people are needed to move the equipment. Do not attempt to move the equipment by one person only.
- Keep balance when moving the equipment, and avoid injuring your leg and feet or spraining your waist.

 Caution

- Do not move the equipment by grasping the panel, power supply handle, or the chassis handle, as they are not designed to bear the weight of the entire equipment. This may cause damage or even injure you.
 - Before moving the switch, remove the supervisor engine, line cards and power supply modules to reduce the weight of the chassis.
 - Install and operate the switch in places where removing is restricted.
-

3.1.3 Electrical Safety

- Please observe local regulations and specifications when performing electrical operations. Relevant operators must be qualified.
- Please carefully check for any potential danger in the working area, for example, ungrounded power supply, unreliable grounding of the power supply and damp ground or floor.

- Find out the location of the emergency power supply switch in the room before installation. First cut off the power supply in case of an accident.
- Be sure to make a careful check before you shut down the power supply.
- Do not place the equipment in a damp location. Do not let any liquid enter the chassis

 Caution

- Any nonstandard and inaccurate electrical operation may cause an accident such as fires or electrical attacks, thus causing severe even fatal damages to human bodies and equipment.
 - Direct or indirect touch through a wet object on high-voltage and mains supply may bring a fatal danger.
-

3.1.4 Static Discharge Damage Prevention

Although the design of the RG-NBS7003 switch considers numerous factors and takes various measures, the circuitry and equipment may be greatly damaged when static electricity exceeds a certain value. In the communication network of the RG-NBS7003 switch, electrostatic induction mainly comes from outdoor high voltage power lines, lightning and other external electric fields, indoor floor materials and the internal structure of the device.

To prevent damage from static electricity, pay attention to the following steps:

- Properly ground the device and floor.
- Keep the indoor installation environment clean and free of dust.
- Maintain appropriate humidity conditions.
- Before installing the various pluggable modules, please wear an anti-static wrist strap and make sure that it is well grounded.
- Do not touch the components and printed circuit board of the module directly with your hands.
- Use an ESD bag to keep the module.
- Avoid clothing and other items in contact with the circuit board. The anti-static wrist strap can only prevent damage to the circuit board caused by static electricity on the body. Static electricity on clothing cannot be prevented.

 Caution

The RG-NBS7000 series switch is equipped with an anti-static wrist strap. See Figure 3-1 for the position of the jack for the wrist strap.

The RG-NBS7000 series switch is equipped with an anti-static wrist strap. To protect electronic components against static electricity, wear an anti-static wrist strap properly and keep it properly grounded while installing swappable modules.

Use an anti-static wrist strap as follows:

- (1) Ensure that the switch is properly grounded.
- (2) Put your hand through the anti-static wrist strap.
- (3) Tighten the buckle till the trap is closely attached to your skin.

⚠ Caution

- For safety, use a multimeter to measure the resistance between yourself and the ground, which should range from 1 Ω to 10 Ω .
 - Make sure that the switch is properly grounded when the anti-static wrist strap is connected to the ground by the jack on the chassis.
-

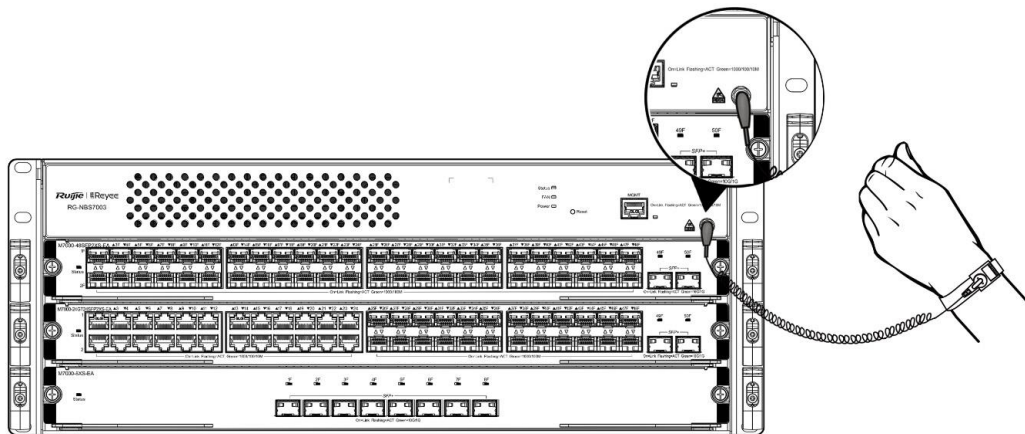
Figure 3-1 Wearing an Anti-Static Wrist Strap

3.1.5 Laser Safety

Among the modules supported by the RG-NBS7000 series switches, there are many transceiver modules that are Class II laser products.

Precautions:

- When a fiber transceiver works, ensure that the port has been connected with a fiber or has been covered by dust cap so as to keep out dust and prevent it from burning your eyes.
- Do not look into any fiber port.

⚠ Caution

Do not look into any fiber port under any circumstances, as this may cause permanent damage to your eyes.

3.2 Installation Site Requirements

You must use the RG-NBS7000 series switch indoors. To ensure the normal operation and prolonged service life of the device, the installation site must meet the following requirements.

3.2.1 Load Bearing Requirements

Evaluate the load bearing requirements for the ground according to the weight of the switch and its accessories (such as the cabinet, chassis, line cards and power supply modules). Make sure the installation site meet the requirements.

3.2.2 Space Requirements

- The width of the machine room corridor should be greater than 0.8 m (31.50 in.) to ensure enough space to move the chassis, and to plug and remove modules.
- Do not install the switch against the wall. Maintain proper clearance around the switch for heat dissipation and switch maintenance.

3.2.3 Ventilation Requirements

See [1.1.7 Heat Dissipation](#) for details of the ventilation design of the switches. Maintain a minimum clearance of 10 cm (3.94 in.) around the switch. After connecting various cables, bundle the cables or place them in the cable management bracket to avoid blocking air intakes.

 **Caution**

Remove all foam packaging materials and protective plastics before you power on the RG-NBS7000 series switches.

3.2.4 Temperature Requirements

To ensure the normal operation and a prolonged useful life of the device, you must maintain an appropriate temperature in the equipment room. Too high or low temperature for a long period may damage the equipment.

- In an environment with high temperature, the equipment is subjected to even greater harm. Too high temperature can accelerate the aging of insulation materials, greatly reducing the reliability of the switch and severely affecting its service life.

The following table shows temperature requirements of the RG-NBS7000 series switches.

Operating Temperature	Storage Temperature
0°C to 50°C (32°F to 122°F)	-40°C to +70°C (-40°F to +158°F)

 **Note**

The ambient temperature of the switch is measured at the point that is 1.5 m (59.06 in.) above the floor and 0.4 m (15.75 in.) before the switch rack when there is no protective plate in front or at the back of the rack.

Recommended cleaning periods:

- (1) Dust intake vents and exhaust vents of all modules every three months.
- (2) Dust line cards every one or two years.
- (3) Dust fan modules yearly.
- (4) Dust the chassis, including the backplane, every one or two years.

 **Note**

If the device is in a dusty environment, please increase the dusting times.

3.2.5 Humidity Requirements

To ensure the normal operation and a prolonged use life of the switch, you must maintain an appropriate humidity in the equipment room. Otherwise, the equipment may be damaged.

- In an environment with high relative humidity, the insulating material may have bad insulation or even leak electricity, and sometimes the materials may suffer from mechanical performance change and metallic parts may get rusted.
- On the other hand, in an environment with low relative humidity, the insulating strip may dry and shrink, and static electricity may occur easily and endanger the circuit on the equipment.

The following table shows humidity requirements of the RG-NBS7000 series switches.

Operating Humidity	Storage Humidity
10% to 90% (non-condensing)	5% to 95% (non-condensing)

i Note

The ambient humidity of the switch is measured at the point that is 1.5 m (59.06 in.) above the floor and 0.4 m (15.75 in.) before the switch rack when there is no protective plate in front or at the back of the rack.

3.2.6 Cleanness Requirements

Dust poses the top threat to the running of the device. The indoor dust falling on the device may be adhered by the static electricity, causing poor contact of the metallic joint. Such electrostatic adherence may occur more easily when the relative humidity is low, not only affecting the service life of the device, but also causing communication faults. The following table shows the requirements for the dust content and granularity in the equipment room.

Dust	Unit	Content
Dust particles (diameter $\geq 0.5 \mu\text{m}$)	Particles/ m^3	$\leq 3.5 \times 10^6$
Dust particles (diameter $\geq 5 \mu\text{m}$)	Particles/ m^3	$\leq 3 \times 10^4$

Apart from dust, the salt, acid and sulfide in the air in the equipment room must also meet strict requirements. Such harmful substances may accelerate metal corrosion component aging. Therefore, the equipment room should be properly protected against the intrusion of harmful gases, such as sulfur dioxide, hydrogen sulfide, nitrogen dioxide, and chlorine gas. The following table lists limit values for harmful gases.

Gas	Average (mg/m^3)	Maximum (mg/m^3)
Sulfur dioxide (SO_2)	0.3	1.0
Hydrogen sulfide (H_2S)	0.1	0.5
Nitrogen dioxide (NO_2)	0.5	1.0
Chlorine gas (Cl_2)	0.1	0.3

Note

The **Average** refers to the average value of harmful gas measured in one week. The **Maximum** value is the upper limit of the harmful gas in one week, and maximum value can last for up to 30 minutes every day.

3.2.7 Power Requirements

The following power supply modules are available:

- For RG-PA300I-FS and RG-PA460I-FS modules, the rated voltage ranges from 100 V AC to 240 V and the frequency ranges from 47 Hz to 63 Hz.

Note

Input power shall be larger than the actual power consumption of the entire system.

Example 1: The NBS7003 chassis is equipped with three M7000-48SFP2XS-EA line cards, or a combination of two M7000-48SFP2XS-EA line cards and one M7000-24GT24SFP2XS-EA line card. The total power consumption of the switch would be: $3 \times 97 \text{ W (M7000-48SFP2XS-EA)} + 45 \text{ W (M7003-FAN (with chassis))} = 336 \text{ W}$ or $2 \times 97 \text{ W (M7000-48SFP2XS-EA)} + 1 \times 75 \text{ W (M7000-24GT24SFP2XS-EA)} + 45 \text{ W (M7003-FAN (with chassis))} = 314 \text{ W}$. In this case, the AC input power should be larger than 336 W or 314 W. You are advised to adopt the RG-PA460I-FS module.

Example 2: The NBS7003 chassis is equipped with two M7000-48SFP2XS-EA modules and one M7000-24SFP2XS-EA. The total power consumption of the switch would be: $2 \times 97 \text{ W (M7000-48SFP2XS-EA)} + 1 \times 58 \text{ W (M7000-24SFP2XS-EA)} + 45 \text{ W (M7003-FAN (with chassis))} = 297 \text{ W}$. In this case, the AC input power should be less than 300 W. You are advised to adopt the RG-PA300I-FS module.

The following table lists the power consumption of each RG-NBS7003 line card:

RG-NBS7003 Series Line Cards	Maximum Power Consumption (W)
M7000-24GT24SFP2XS-EA	75
M7000-48GT2XS-EA	54
M7000-24GT2XS-EA	41
M7000-48SFP2XS-EA	97
M7000-24SFP2XS-EA	58
M7000-8XS-EA	44
M7000-16XS-EA	82
M7003-FAN (Including the chassis)	45

⚠ Caution

- The RG-NBS7003 switch provides 1+1 power redundancy. You are advised to use multiple power supplies for the equipment to ensure its continuous and stable operation by avoiding the impact of unexpected power failures on the equipment.
 - When the multiple power supply modules are applied, they must be of the same type.
 - If a power supply system is equipped with a leakage protector (leakage current switch or breaker), the rated leakage action current of each leakage protector is twice greater than the theoretical maximum leakage current of all the power supplies in the system. For example, if a system is equipped with eight identical power supplies, the leakage current of each power supply is equal to or less than 3 mA, and the leakage current of the system totals 24 mA. A leakage protector with 30 mA rated action current supports less than five power supplies (that is, Action current of the leakage protector/2/Maximum leakage current of each power supply = $30/2/3 = 5$). In other words, the leakage protector with 30 mA rated action current supports no more than four power supplies. In this case, the eight power supplies in the system require at least two leakage protectors with 30 mA rated action current and each leakage protector supports four power supplies. If power supplies in a system differ in models, the rated leakage action current of each leakage protector divided by two is greater than the sum of maximum leakage current of all the power supplies. The rated leakage non-action current of a leakage protector must be 50% of the leakage action current. The leakage protector with 30 mA rated leakage action current is used as an example. The rated leakage non-action current must be 15 mA. When the leakage current falls below 15 mA, the protector should not act. Otherwise, misoperation may easily occur due to high sensitivity and thus the leakage protector trips, devices are powered off, and services are interrupted.
 - To guarantee personal safety, the rated leakage action current of each leakage protector in the system must be equal to or less than 30 mA (human body safety current is 30 mA). When twice of the total leakage current of the system is greater than 30 mA, the system must be equipped with two or more leakage protectors.
 - For the leakage current value of each power supply model, see the "Specification" tables of power supply modules in Chapter 2.
-

3.2.8 System Grounding Requirements

A good grounding system is the basis for the stable and reliable operation of the RG-NBS7000 series switches. It is the key to prevent lightning stroke and resist interference. Carefully check the grounding conditions on the installation site according to the grounding requirements, and perform grounding properly as needed.

Safety Grounding

The equipment using AC power supply must be grounded through a yellow/green safety grounding cable. Otherwise, when the insulating resistance decreases the power supply and the enclosure in the equipment, an electric shock may occur.

⚠ Caution

The building installation shall provide a protective ground connection to ensure that the device is connected to a protective earth.

Lightning Grounding

The lightning protection system of facility is a separate system that consists of a lightning rod, down lead conductor and connector to the grounding system, which usually shares the power reference ground and

yellow/green safety cable ground. The lightning discharge ground is for the facility only, irrelevant to the equipment.

 Note

For switch lightning protection, see Appendix C.

EMC Grounding

The ground required for EMC design includes shielding ground, filter ground, noise and interference suppression, and level reference. All the above constitute the comprehensive grounding requirements. The grounding resistance should be less than 1Ω . One grounding point is reserved at the left rear of the chassis. The grounding point is pasted with a conspicuous warning label. See Figure 1-3 for details.

3.2.9 EMI

Various interference sources, from either outside or inside the equipment or application system, affect the system in the conductive ways such as capacitive coupling, inductive coupling, and electromagnetic radiation. There are two types of electromagnetic interferences: radiated interference and conducted interference, depending on the type of the propagation path. When the energy, often RF energy, from a component arrives at a sensitive component via the space, the energy is known as radiated interference. The interference source can be both a part of the interfered system and a completely electrically isolated unit. Conducted interference results from the electromagnetic wire or signal cable connection between the source and the sensitive component, along the cable the interference conducts from one unit to another. Conducted interference often affects the power supply of the equipment, but can be controlled by a filter. Radiated interference may affect any signal path in the equipment, and is difficult to shield.

- Take effective measures for the power system to prevent the interference from the electric grid.
- The working ground of the switches should be properly separated and kept as far as possible from the grounding device of the power equipment or the anti-lightning grounding device.
- Keep the equipment away from high-power radio transmitter, radar transmitting station, and high-frequency large-current device.
- Take measures to isolate static electricity if necessary.

3.3 Cabinet Mounting

Make sure the cabinet complies with the following conditions if you want to install the switch in a cabinet:

- Install the switch in a 19-inch cabinet in 4-post form hold.
- Be sure the distance between two square hole strips, one on each side, is 465 mm (18.31 in.).

Figure 3-2 19-inch Cabinet

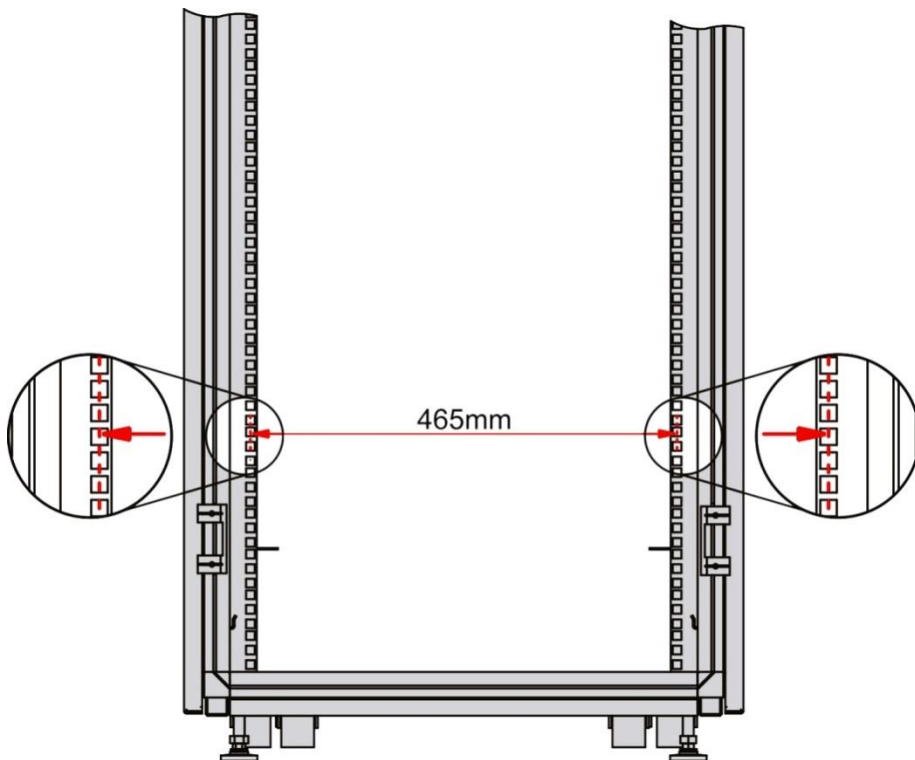

- Be sure that the square hold strip is at least 125 mm (4.92 in.) far from the outboard front door and the door is at most 25 mm (0.98 in.) thick to ensure a minimum available distance of 100 mm (3.94 in.). The front door is at least 500 mm (19.69 in.) far from the back door.

Figure 3-3 Cabinet Dimensions

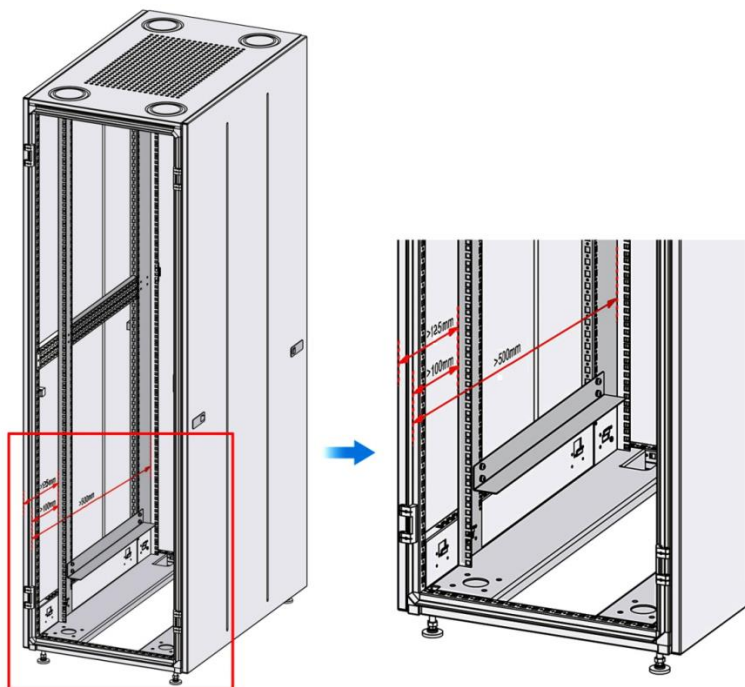

- Be sure that the slide rail in the cabinet is enough to bear the weight of a switch and its installation accessories.
- Be sure that the cabinet provides a grounding point for the switch to be grounded.

- Be sure that the front and back doors of the cabinet have porosities greater than 50% for good ventilation and heat dissipation.

3.4 Installation Tools

Common Tools	Phillips screwdriver, related Ethernet and fiber-optic cables, cage nuts, diagonal plier, and cable ties
Special Tools	Anti-static wrist strap, wire stripper, crimping plier, and wire cutter
Fiber Optic Cleaning Tools	Dust-free paper and fiber end-face microscope
Meter	Multimeter, bit error rate tester (BERT), and optical power meter

 Note

The switch is not delivered with a tool kit. The tool kit is customer-supplied.

3.5 Precautions for Fiber-Optic Cable Connection

Before connecting fiber-optic cables, make sure the model of the optical module and fiber type match the optical port. The transmit port on the local device should be connected to the receive port on the peer device and vice versa.

3.6 Unpacking

Package Contents

Chassis Kit	Device panels are installed and commissioned. Switch, fans, cable management brackets, anti-static wrist strap, yellow/green grounding cables, screws, cage nuts, user manual, package contents
Module Kit	Modules, package contents, documentation

 Note

The package contents generally contain the preceding items. The actual delivery is subject to the order contract. Please check your goods carefully against the order contract. If you have any questions, please contact the distributor.

4 Installing the Switch

The RG-NBS7000 series switches must be used and fixed indoors.

Note

Ensure that you have carefully read Chapter 2 and make sure that the requirements in Chapter 2 are all met.

4.1 Installation Procedure

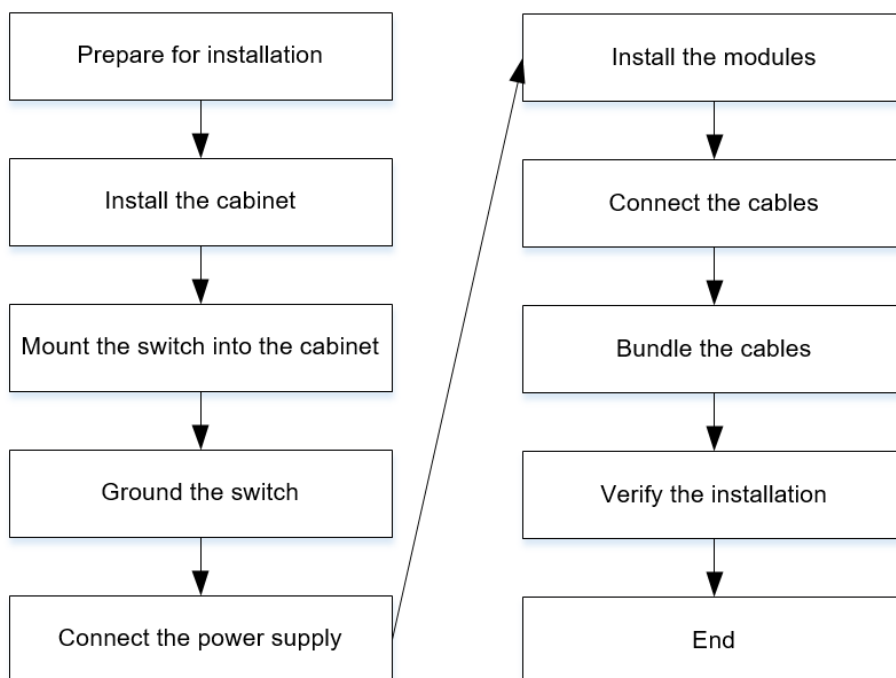

4.2 Before You Begin

Carefully plan and arrange the installation location, networking method, power supply, and wiring before installation. Verify the following requirements before installation:

- The installation location provides sufficient space for heat dissipation.
- The installation site meets the temperature and humidity requirements of the switch.
- The power supply and required current are available at the installation site.
- The Ethernet cables have already been deployed at the installation site.
- The selected power supply meets the system power requirement.

4.3 Mounting Cable Management Frames

Note

- Wear an anti-static wrist strap and ensure that the anti-static wrist strap is grounded well.
- The cable management brackets are not mounted before delivery. See the following steps and figures for installation.

- Mount cable management brackets for the RG-NBS7003 switch:

- (1) Take out cable management brackets from chassis accessories.
- (2) As shown in Figure 4-1, there are three cable management brackets on each side respectively. Pay attention to the direction to mount the cable management brackets.
- (3) Align the screw holes on the cable management brackets with those on the chassis and tighten the screws.

Note

If you want to install a cable management bracket to slot 3, remove the screw at the bottom of the bracket.

Figure 4-1 Mounting Cable Management Frames

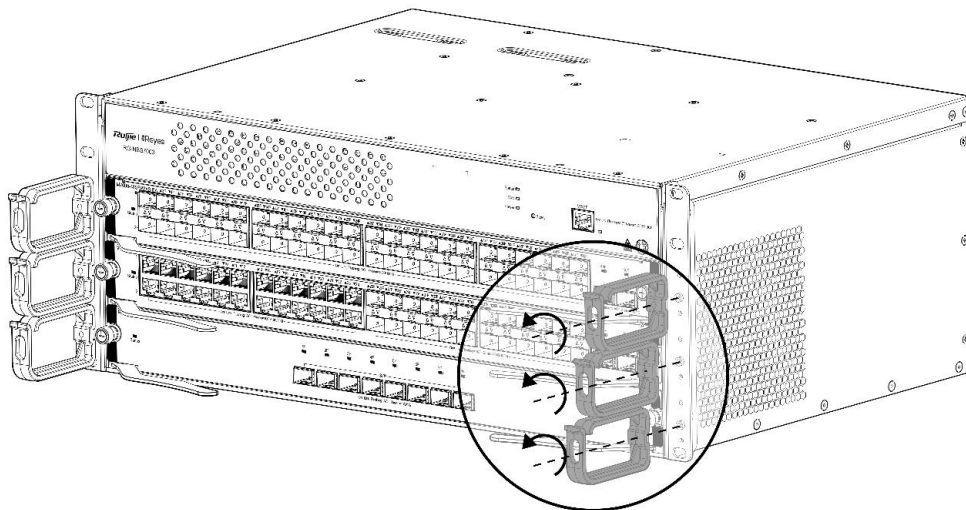

4.4 Mounting the Cabinet

Precautions

- When you install the cabinet, pay attention to the followings:
- All expansion bolts for fastening the cabinet base to the ground should be installed and tightened in sequence from bottom to up (large flat washer, spring washer, and nut), and the installation holes on the base and the expansion bolts are properly aligned.
- The installed cabinet should not be moved.
- The installed cabinet should be vertical to the ground.
- When multiple cabinets are placed side by side in the equipment room, they should be aligned with each other, leaving an error less than 5 mm (0.20 in.).

- The front/rear doors of the cabinet should be installed to allow you open and close them smoothly. The locks should work normally, and all keys should be complete.
- There should be no unnecessary and informal labels inside the cabinet and on line cards.
- Filler panels are installed in the empty slots.
- The screws in the cabinet should be fastened tightly and be of the same model.
- The device is securely installed, and the screws on the panel should be fastened tightly.
- All wiring outlets at the top and bottom of the cabinet should be installed with rodent-resistant nets with clearance of no more than 15 mm (0.59 in.) in diameter to prevent rodents and other small animals from entering the cabinet.
- Antistatic wrist straps should be provided in the cabinet.

Installation Steps

- (1) Plan the available space before installing the cabinet. Reserve enough space for the front and rear doors for device maintenance.
- (2) Install and secure the cabinet in the designed position as planned.
- (3) Install the appropriate cable troughs and cables.
- (4) Install the tray and slide rails on the rack according to the number of devices installed into the cabinet.

Installing Slide Rails

Before installing a slide rail, learn about standard 19-inch cabinets of IEC60297. The height of standard cabinets is measured in Rack Unit (RU). 1 RU is equal to 44.45 mm (1.75 in.), which is the length of three holes (see Figure 4-2). The hole in the middle is an auxiliary installation hole, and the other holes are standard installation holes. Note that the space between neighboring standard installation holes is a little smaller than that between an auxiliary installation hole and its neighboring standard installation hole. When installing a slide rail for the switch, ensure that the plane to carry the chassis should be installed on the plane of delimiters (entire-U delimiter) of the two neighboring RUs as shown in Figure 4-2.

Figure 4-2 Slide Rail

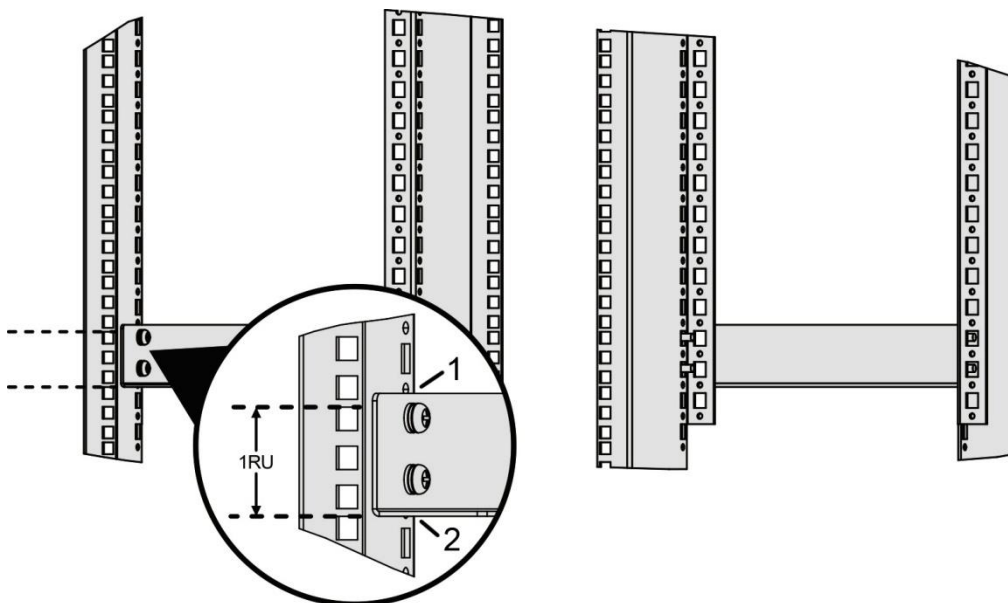

1 and 2 represents entire-U delimiters

 **Caution**

- Before installing a slide rail, make sure that the bearing capacity of the slide rail meets requirements.
- There are various slide rails. The rail appearance and installation method is subject to actual conditions.
- To keep the cabinet balanced, install the slide rail to as low as possible in the cabinet if only one RG-NBS7000 series switch is installed. If you are mounting multiple devices to the cabinet, mount the heaviest device in the lowest position of the cabinet first and mount the rest of the devices from bottom to top.
- You are advised to plan available space to install the power socket properly. Otherwise, there may be problems for operation.

4.5 Mounting the Switch to a Cabinet

Precautions

Before mounting the RG-NBS7000 series switches into the cabinet, first verify the rack posts. If the rack post is too close to the front door, the front door may not be closed when network cables and fiber-optic pigtails are connected. Reserve at least 10 mm (0.39 in.) between the rack post and the front door after installation. Confirm the followings before mounting the switch:

- The cabinet is fixed.
- All the modules in the cabinet is installed properly.
- Remove any obstacle inside or surrounding the cabinet.
- Prepare the switch and move it to the place near the cabinet where you can handle it easily.

 **Note**

Three people are recommended for handling the switch. One is responsible for directing and the other two carrying or lifting the switch.

Installation Steps

- (1) Measure the height of the brackets and identify the location of the brackets based on the plane bearing the switch. Mark the location of the brackets and install the cage nuts.

Figure 4-3 Slide Rail Installation Positions

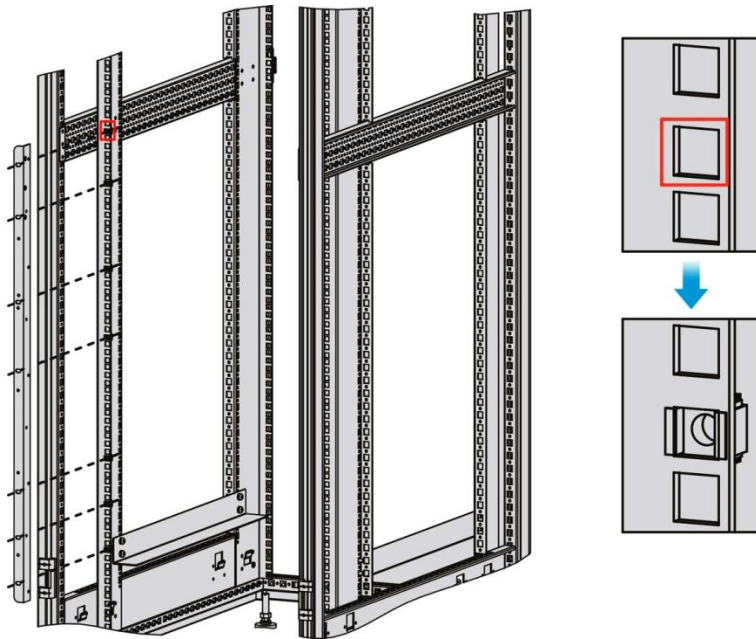

- (2) Place the switch on the slide rail, and drive it smoothly into the cabinet until the bracket reaches the square hole strip.
- (3) Align the installation holes on the bracket with the cage nuts on the square hole strip, and drive screws into the holes.

Figure 4-4 Mounting the Switch into a Standard 19-inch Cabinet

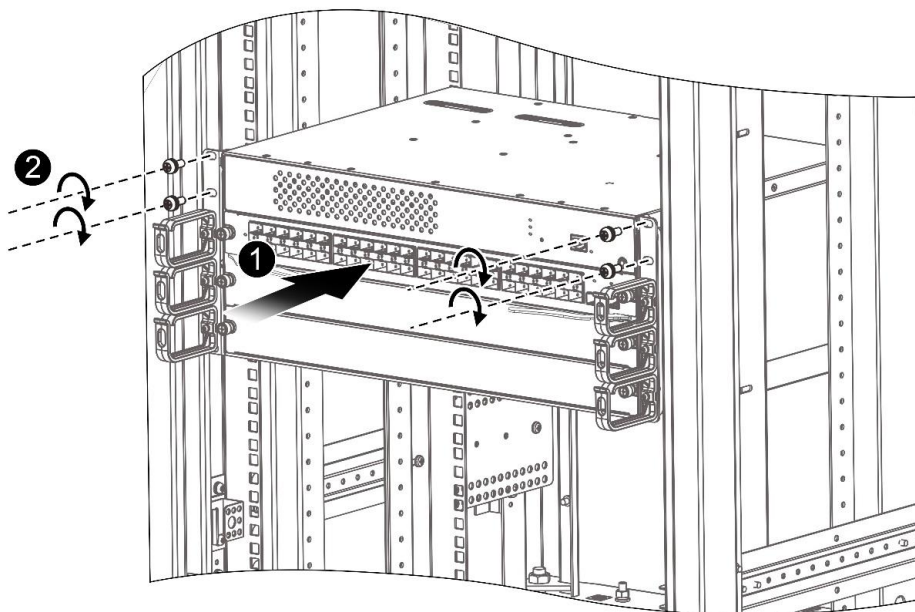

4.6 Grounding the Switch

Note

A good grounding system protects your switch against lightning strikes and interferences and ensures its normal operation and reliability.

Precaution

- The sectional area of the grounding wire should be determined according to the possible maximum current. Cables with good conductor should be used.
- Do not have bare wires exposed.
- To guarantee the security of the person and the device, the switch must be grounded properly. The grounding resistance between the chassis and the ground should be less than 1Ω .

Connecting the System Ground

To connect the system ground, follow these steps:

- (1) Remove the two screws on the rear of the switch.
- (2) Attach one end of the grounding wire to the switch with the two screws. Connect the other end of the grounding wire to the grounding wire of the cabinet or the grounding bar of the equipment room.

Figure 4-5 Grounding Point on the Rear Panel

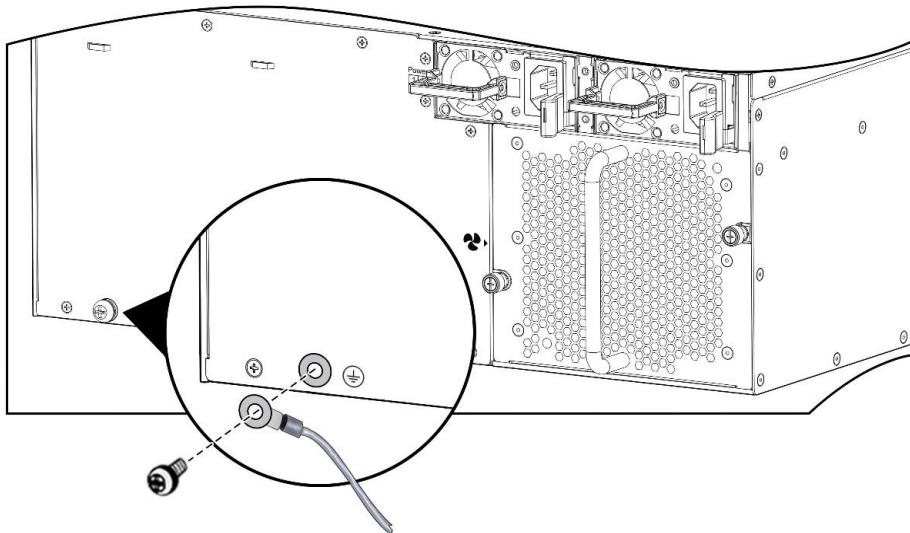

Caution

- To guarantee the security of the person and the device, the switch must be grounded properly. The grounding resistance between the chassis and the ground should be less than 1Ω .
- The maintenance personnel should check whether the AC socket is reliably connected to the protective ground of the building. If not, the maintenance personnel should use a protection ground wire to connect the protection ground terminal of the AC socket to the protection ground of the building.

- The power socket should be installed near the device and easily accessible.
- When installing the switch, connect the grounding first and disconnect it last.
- The cross-sectional area of the protection ground wire should be at least 2.5 mm² (12 AWG).

4.7 Installing a Power Supply Module

The RG-NBS7003 switch provides two power supply models: RG-PA300I-FS and RG-PA460I-FS. Before performing the following procedures, wear an anti-static wrist strap close to your skin and have it properly grounded.

⚠ Caution

- The switch provides two power supply module slots. You are advised to configure 1+1 redundancy.
- If the switch is powered up by two power supply modules, they must be in the same model.
- To carry or lift the power supply module, hold the bottom of the module instead of carrying the module by the handle. Otherwise, the module may be damaged.
- Before inserting or removing the power supply module, verify whether the switch is well mounted. Because the switch is tall, prevent the switch from tumbling down when you are inserting or removing the power supply module.
- After hot swapping a power supply module, wait for at least 30 seconds for the next hot swapping.
- Do not touch the connecting finger part of the removed power supply module in case the capacitor is not fully discharged.

- (1) Loosen the captive screws on the filler panel over the power supply slot in the rear of the switch.
- (2) Slide the power supply module into the slot along the guide rail slowly until the module snaps into place.

Figure 4-6 Installing a Power Supply Module

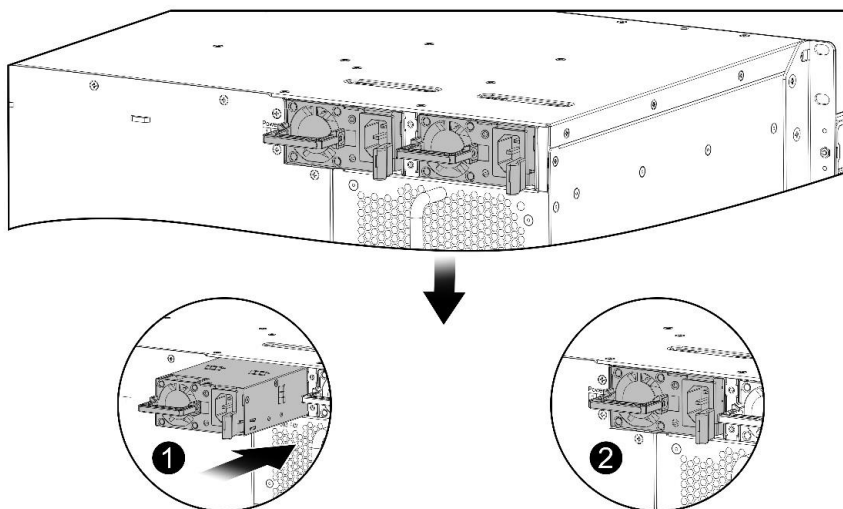

⚠ Caution

- The total power of installed power supply modules must be greater than the working power of the switch. Otherwise, some modules may fail to work.
 - The switch power is the sum of the power of all working modules, including the supervisor engine, line cards and fan modules. For the power consumption of each module, see [Power Requirements](#).
-

4.8 Installing a Fan Module

The switch adopts the M7003-FAN module for heat dissipation. Before performing the following procedures, wear an anti-static wrist strap close to your skin and have it properly grounded.

- (1) Install the fan module into the fan slot according to the orientation marked on the module.
- (2) Tighten the captive screws on the fan module with a screwdriver.

Figure 4-7 Installing a M7003-FAN Module

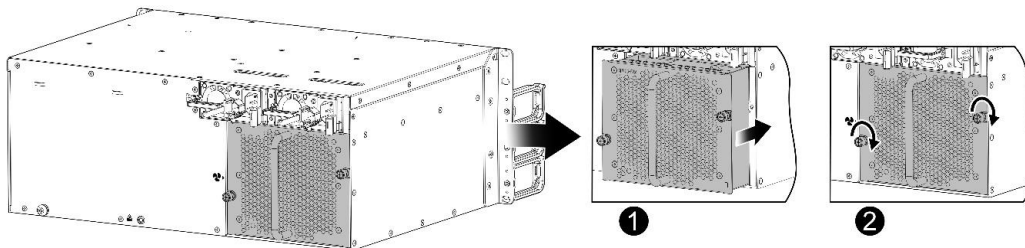

⚠ Caution

- Do not remove the fan module with force. Use the fan handle instead. Otherwise, components may be damaged and the distorted fan module cannot be removed.
 - For hot swapping of fan modules, see Hardware Maintenance.
-

4.9 Installing a Supervisor Engine or Line Card

Wear an anti-static wrist strap close to your skin and have it properly grounded. Do not touch any component of the module for safety.

⚠ Caution

- Do not hold the edge of the PCB or touch the components on the PCB.
 - Do not insert or remove a supervisor engine, line card or switch fabric module with force, use the ejector levers on both sides of the panel instead.
-

i Note

- Any line card can work as a supervisor engine in slot 1 (slot 1 must be occupied).
 - To swap the supervisor engine slot and the line card slot, reset the switch to factory settings.
 - Press the **Reset** button for over 5 seconds to reset all modules and restore the modules to factory settings with configuration backup saved. After restart, use the default password to log in to the Web management
-

system. You can select **Reset Backup** to restore previous configurations, or select **Delete Backup** to delete previous configurations. See Figure 1-2 for the **Reset** button.

- Remove the filler panel in a slot before installing a line card.

Figure 4-8 RG-NBS7003 Supervisor Engine Slots and Line Card Slots

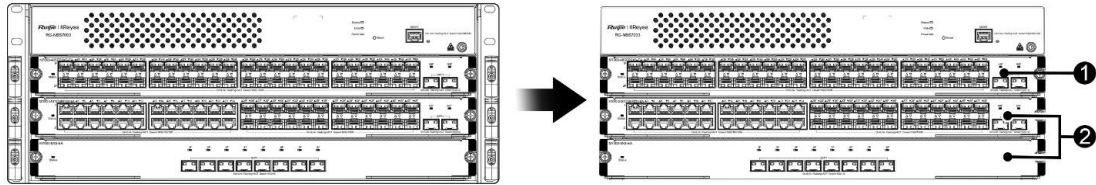

1. Slot 1 (supervisor engine)	2. Slot 2 and Slot 3 (line card)
-------------------------------	----------------------------------

- (1) Rotate the ejector levers away from the front of the module, as shown in step 4 in Figure 3-9.
- (2) Insert the module into the slot along the rail and slide it slowly into the chassis, as shown in step 5 in Figure 3-9.
- (3) Rotate the ejector levers toward the front of the module, as shown in step 6 in Figure 3-9.
- (4) Tighten captive screws on both sides of the filler panel, as shown in step 7 in Figure 3-9.

Figure 4-9 Installing the RG-NBS7003 module

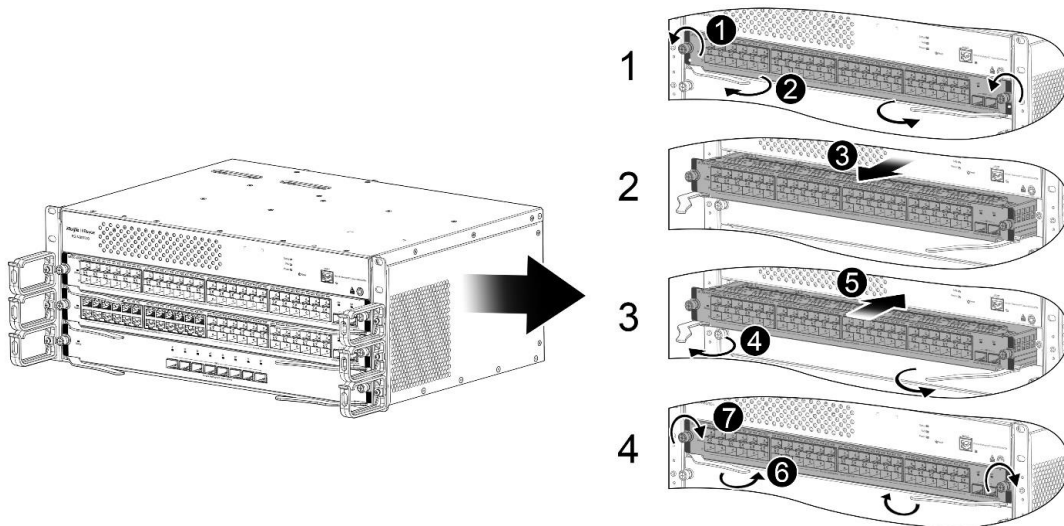

⚠ Caution

Install filler panels to unoccupied slots for heat dissipation.

4.10 Installing an SFP or SFP+ Module (Optional)

⚠ Caution

Make sure the optical modules connected to both ends of a fiber-optic cable are of the same model.

Preparation

- (1) To avoid damages to SFP or SFP+ modules and electronic components in the device caused by the static electricity generated during the installation, wear an anti-static wrist strap close to your skin and have it properly grounded.
- (2) Take out the SFP or SFP+ modules you want to install from the packing bag. Do not touch the connecting finger on the module.

Figure 4-10 Wearing an Anti-Static Wrist Strap

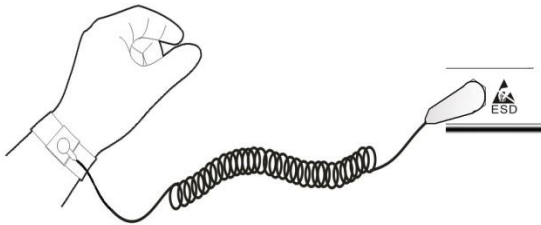

Installing an SFP or SFP+ Module

⚠ Caution

To avoid damaging components due to operation errors, read this section carefully before installing the SFP or SFP+ module.

- (1) Open the bale clasp on the SFP or SFP+ module with your index finger in an upward direction. Grasp the module between your thumb and index finger and carefully push it into the port until it snaps into place.

Figure 4-11 Installing the SFP Module

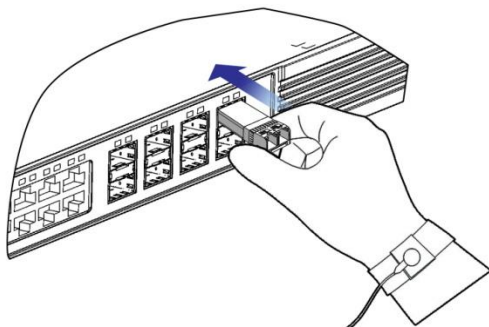

- (2) Use a fiber optical patch cord to connect the SFP or SFP+ module to the fiber optical network. Select a patch cord with a connector according the port type.
- (3) After the patch cord is connected, the Link/ACT Status LED is on. Otherwise, check connection of the patch cord.

Precautions

- The optical module cannot be inserted inversely. If the optical module cannot be inserted to the end, do not push it with force. Please try the other end of the module.
- Do not remove the rubber plug from the SFP or SFP+ module before connecting the fiber-optic cable.
- Do not insert the SFP or SFP+ module with a fiber-optic cable into a slot. Unplug the fiber before installing the module.
- Do not touch the connecting finger on the module during installation.
- Do not squeeze, twist, fold or excessively bend the fiber-optic cable, which may cause system performance degradation or data loss.

4.11 Connecting the Power Cord

Connect the power cord according to the instruction on the power supply module panel, including RG-PA300I-FS, RG-PA460I-FS, and RG-PA600I-FS.

Note

Make sure the socket is powered off before the power cord is connected.

- (1) Insert the AC power plug into the power connector.
- (2) Take out the cable retention clip from the accessories.
- (3) Install the cable retention clip onto the power supply module.
- (4) Rotate the cable retention clip on the power supply module over the power plug.
- (5) Connect the other end of the power cord to an external power source.

Figure 4-12 Connecting the Power Cord

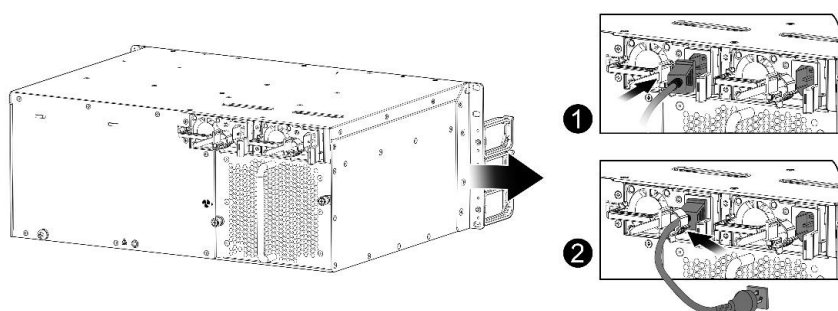

Caution

Please use a 3-pin power cord. The minimum cross-sectional area of each pin is 1.5 mm² or 14 AWG.

The RG-NBS7003 power supply module uses a 10 A power cord. Adopt a proper socket and verify the AC power supply capacity in the equipment room.

4.12 Installation Verification

 Note

Make sure all power supplies are cut off before checking the installation to avoid personal injury and device damage.

Before powering up the switch, please verify the following requirements:

- Verify if the external power supply matches the distribution panel of the cabinet.
- After installing the equipment, verify if the front/back cabinet doors can be closed.
- Verify that the cabinet has been fastened completely, and does not move or tilt.
- Verify that the equipment has been installed in the cabinet, and all the cables have been fastened to the cabinet.
- Verify that the fan meets the requirement.
- Verify that the power supply is properly selected.
- Verify that the power module is inserted properly, and the captive screws are tightly fastened.
- Do not power up the switch by yourself and do not perform live-line maintenance.
- Verify that there is no potential danger in the working area, for example, the power supply is not grounded well, or the ground is wet.
- Do not place the switch at a damp place to prevent the moisture from entering the switch.
- Be sure of the location of the emergency power switch. If an emergency occurs, cut off the power first.
- Verify that all power supplies are turned off if you want to turn off the power.
- Verify that the power cord is connected properly.
- Verify that the power cord is long enough to avoid being stretched.
- Verify that the rated current of the external power socket is greater than 10 A and that the socket is grounded properly.
- Verify that each power module is connected to a power socket.
- Verify that the vacant slot is covered with a filler panel for ventilation and heat dissipation.

5 Verifying Operating Status

5.1 Establishing the Configuration Environment

Configuring Terminal Parameters

Figure 5-1 Configuration Environment of the RG-NBS7003

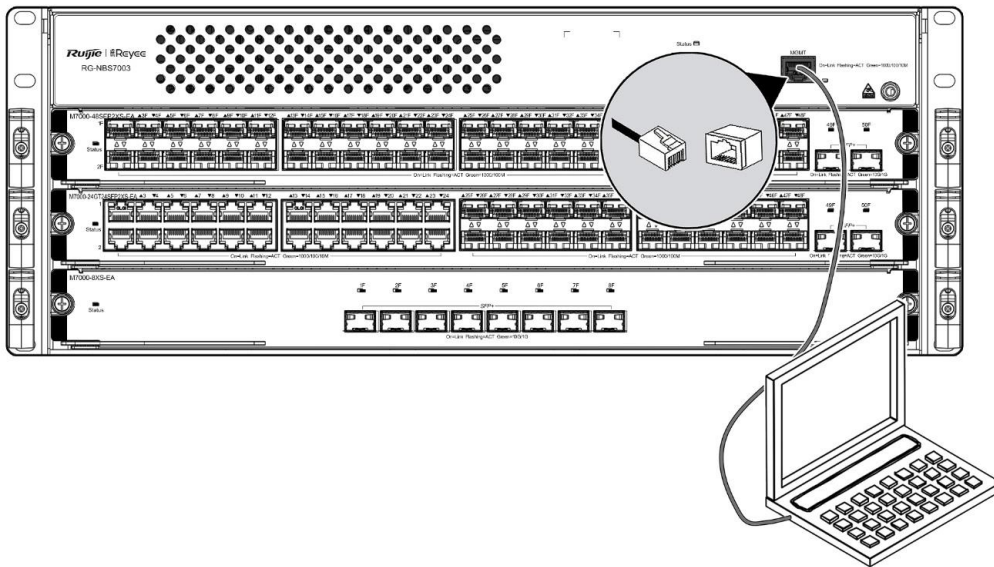

Connecting the Cable

- Connect the end of the cable with a crystal connector to the network port of the PC.
- Connect the end of the cable with a RJ45 connector to the management port of the switch.

Logging in to the Device

- Configure the PC with an IP address 10.44.77.XXX (Range: 1-255, 200 excluded).
- Open a browser and enter 10.44.77.200 into the address bar of the browser. Press **Enter** to navigate to the login page.

5.2 Power-on Startup

Checklist Before Power-on

- The switch is fully grounded.
- The power cable is correctly connected.
- The power supply voltage complies with the requirement of the switch.
- The cable is correctly connected; the terminal (can be a PC) used for configuration is already started; the parameters are already configured.

Checking after Power-on (Recommended)

After power-on, you are advised to perform the following checks to ensure the normal operation of follow-up configurations.

- Check that the device indicator is normal.

6 Monitoring and Maintenance

6.1 Monitoring

LED

When the switch is running, you can monitor the status of each module by observing the status LEDs.

- When the status LED of the chassis is red, it means a module is faulty. Log in to the Web management system to perform troubleshooting.
- When the status LED of the chassis is yellow, it means there is a fault affecting system performance, such as a temperature alarm, a fan module out of position or a faulty supervisor engine. However, the system may continue running. Log in to the Web management system to perform troubleshooting.
- When the status LED of the fan module is red, it means that the fan module is faulty. Log in to the Web management system to perform troubleshooting.
- When the Status LED of the power supply module is red, it means that the power supply module is faulty. Log in to the Web management system to perform troubleshooting.
- When the Status LED of a supervisor engine or line card is off or continues blinking, it means that the module is faulty. You need to identify the cause, and turn off the power if necessary.

6.2 Hardware Maintenance

Supervisor Engine or Line Card Maintenance

The RG-NBS7003 allows any line card to work as a supervisor engine in slot 1. Follow instructions in [Installing a Supervisor Engine or Line Card Product Installation](#) to replace or remove a faulty module.

Ventilation System Maintenance

- The fan in the equipment responsible for heat dissipation is provided with the fault monitoring signals. When the fan fails, a corresponding alarm will occur.
- Loosen the captive screws on the fan module.
- Replace the faulty fan module with a qualified one.
- Tighten the captive screws of the fan module.

 Caution

Complete fan replacement within 30 seconds when the device is powered on.

Power Supply Maintenance

When the power supply fails, you only need to disconnect the power cable, unplug the power module, replace it with a qualified one, and then connect the power cables.

Fuse Replacement

Please contact the technical support representatives of Ruijie Networks for replacing fuses. Technical staff of Ruijie Networks will replace the fuse of the same model.

The following table lists the specifications of the fuse for each module.

Module	Fuse Slot Number	Fuse Specification
M7000-24GT24SFP2XS-EA	F1	F 15 A/85 V
M7000-48GT2XS-EA	F1	F 15 A/85 V
M7000-24GT2XS-EA	F1	F 10 A/125 V
M7000-48SFP2XS-EA	F1, F2	F 15 A/85 V
M7000-24SFP2XS-EA	F1	F 15 A/125 V
M7000-8XS-EA	F1	F 10 A/125 V
M7000-16XS-EA	F1	F 15 A/125 V
M7006-CM	F1	F 10 A/125 V
M7003-FAN	F1	F 10 A/125 V
M7006-FAN	F1	F 10 A/125 V

7 Troubleshooting

7.1 Troubleshooting Flowchat

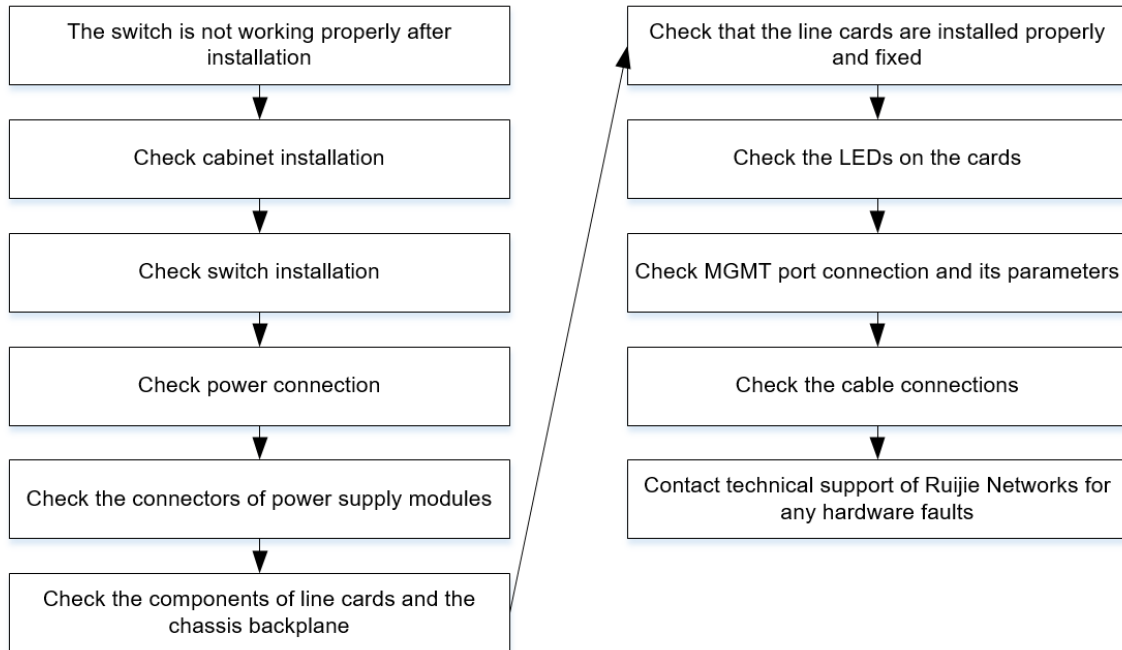

7.2 Common Troubleshooting

Fault 1: The power supply module does not work.

Symptom

The Status LED of each line card is off, the Status LED of the fan is off, and the fan does not work. The LED on the panel of the power module is off.

Suggested Action

- (1) Unplug the power cords from all the power supply modules and ensure they are power-off. Check if the cables of the cabinet have been correctly connected.
- (2) Check whether the cabinet power sockets are loosely connected to power modules. Check whether the power cord is loosely connected to the power module.
- (3) Check whether the power module is installed correctly. If necessary, pull out the power modules and check whether the connectors on the backplane of the power system are loose.
- (4) Check whether the output of the power supply meets the requirement of the power consumption of the device. If not, please purchase extra power supply modules.

Fault 2: An LED error occurs when line cards are powered on.

Symptom

The Status LED of the line card is off or continuously blinking. The Link/ACT LED of the line card is solid on when no network cable or fiber-optic cable is connected.

Suggested Action

- (1) Check if the line card is firmly inserted. If not, install the line card again and ensure that it is inserted into place before you tighten the captive screws on the two sides of the panel.
- (2) If the line card still does not work, check if the connector of the slot on the backplane is loose. If yes, insert the line card to another slot for a try.
- (3) Press the Reset button for over 5 seconds to restore to factory settings.
- (4) If the slot and connection are not the cause, return the line card for repair.

Fault 3: The LED is abnormal after a line card works for some time.

Symptom

The Status LED of the line card is off. The Link/ACT LED of the line card is solid on when no network cable or fiber-optic cable is connected. The fault remains after restart.

Suggested Action

- (1) Check if the line card gets loose. If so, install the line card again and ensure that it is inserted into place before you tighten the captive screws on the two sides of the panel.
- (2) If the module still does not work, check if the connector of the slot on the backplane is loose or the slide rail of the slot is deformed. If so, insert the line card to another slot for a try.
- (3) If the slot and connection are not the cause, return the line card for repair.

Fault 4: The fan does not work or the LED is abnormal.

Symptom

After the system starts, the fan is not powered on and the status LED is red.

Suggested Action

- (1) Check if the connection between the fan module and the backplane is secure and if the connector gets loose.
- (2) If the connection is secure, you need to replace the fan module.

Fault 5: The new line card fails to work properly.

Symptom

The system runs normally, yet the LED on the panel of the newly-inserted line card keeps blinking, and the port is faulty.

Suggested Action

The RG-NBS7000 series switches do not support hot swapping of line cards. Power off the switch to insert a line card.

Fault 6: The link cannot be set up between optical ports.

Symptom

The system runs normally. After you insert the optical module into the optical port and connect the fiber-optic cable properly, the link cannot be set up.

Suggested Action

- (1) Check whether the receiving and sending ends are wrongly connected. The sending end of the fiber port needs to be connected to the corresponding receiving end. You can check by changing the sequence in which the two fiber-optic cables are connected on the optical module.
- (2) Check whether the optical module wavelengths of the two sides are consistent. For example, an optical module of 1310nm wavelength cannot be connected to an optical module of 1550nm wavelength.
- (3) Check whether the distance between the two sides exceeds the length indicated on the optical module.
- (4) Check whether the rates of the two sides match and whether the fiber-optic cable type meets requirements. In addition, for ports supporting different rates, check whether rate modes are configured correctly.

Note

If preceding methods do not take effect, please contact Ruijie Networks for technical support.

8 Replacing Modules

8.1 Removing an SFP or SFP+ Module

- (1) Unplug the fiber-optic cable.
- (2) Turn down the handle of the module until it is horizontal. Pull the tab to take out the SFP or SFP+ module, as shown in Figure 8-1.

Figure 8-1 Removing an SFP or SFP+ Module

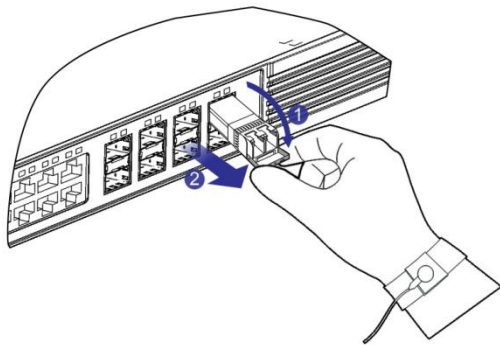

Precaution

- Unplug the fiber-optic cable before removing the module.
- Do not pull out the module forcefully without turning down the handle of the module.
- Immediately install the dust plug to the module connector and the switch optical port.

8.2 Replacing a Supervisor Engine or Line Card

Any line card can work as a supervisor engine in slot 1. Slot 1 must be occupied.

Preparation

- (1) Wear an anti-static wrist strap close to your skin and have it properly grounded.
- (2) Take out the module from the package.

Steps

- (1) Unplug all cables such as fiber-optic cables and RJ45 twisted pairs from the panel.
- (2) Untighten the captive screws on the filler panel, as shown in step 1 in Figure 8-2.
- (3) As shown in step 2 in Figure 8-2, rotate the ejector levers away from the front of the module to separate module from the backplane.
- (4) As shown in step 3 in Figure 8-2, hold the ejector levers to pull out the module along the guide rail. Hold the module with one hand and place your other hand under the module to support its weight.
- (5) As shown in step 4 in Figure 8-2, rotate outward the ejector levers on both sides of the module to be installed.

- (6) As shown in step 5 in Figure 8-2, place one hand under the module to support its weight and hold the module with your other hand. Push the module into the slot along the guide rail.
- (7) As shown in step 6 in Figure 8-2, rotate the ejector levers toward the front of the module.
- (8) As shown in step 7 in Figure 8-2, tighten the captive screws on the filler panel.

Figure 8-2 Replacing a Supervisor Engine or Line Card

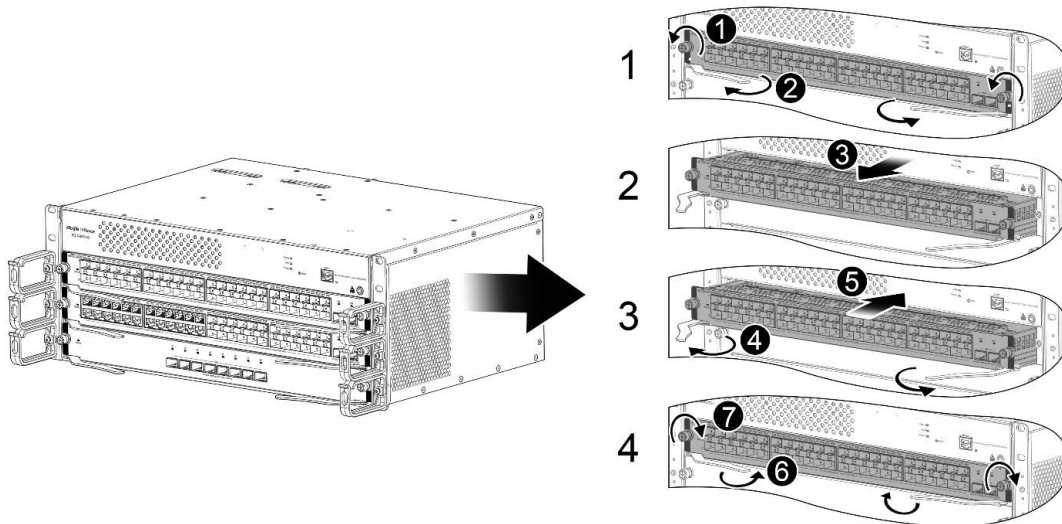

⚠ Caution

- In order to ensure the reliability of the system ventilation and heat dissipation performance and address the requirement of the dust-filter, filler panel needs to be installed in a vacant slot.
- The RG-NBS7000 series switches do not support hot swapping of line cards. Power off the switch to replace a line card.
- Do not hold the edge of the PCB or touch the components on the PCB.
- Do not plug or unplug a line card with force, use the ejector levers on both sides of the filler panel instead.

8.3 Replacing a Power Supply Module

Preparation

- (1) Wear an anti-static wrist strap close to your skin and have it properly grounded.
- (2) Take out the power supply module from the package.
- (3) Power off the module before removing it.

⚠ Caution

- After hot swapping a module, please wait for at least 30 seconds for the next operation.
- Before inserting or removing the power module, please verify whether the switch is well mounted. Prevent the switch from tumbling down when you are inserting or removing the power module.
- Do not touch the connecting finger on the power module which has been removed to avoid being electrocuted in case of incomplete discharge.

Steps

- (1) Unplug the cable. Separate the pigtail plug of the cable from the connector of the power supply module.
- (2) Grasp the handle of the module and pull firmly to slide the power supply halfway out of the chassis.
- (3) Hold the front of the module with one hand and hold the bottom of the module with the other hand to pull it slowly from the slot.
- (4) Slide the new module into the slot until it clicks into place.

Figure 8-3 Replacing the Power Supply Module

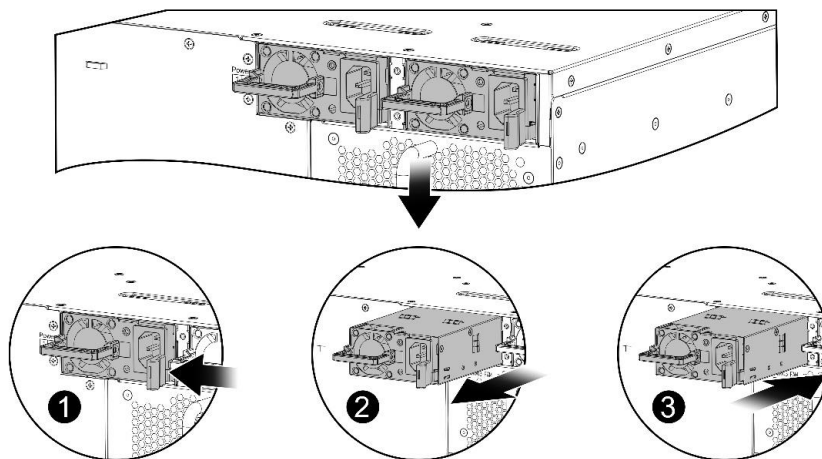

8.4 Replacing a Fan Module

⚠ Caution

- Do not touch any bare wire, terminal or the power instruction on the switch to avoid personal injury.
- The fan module supports hot swapping. If you want to remove the fan module when the switch is operational, do not remove the fan module until the fan stops rotating. As the fan may rotate for a while, to avoid personal injury, do not put your hands inside the fan tray.
- If you remove the fan module when the switch is working, install another fan module quickly to ensure normal operation of the switch and avoid damage to the switch.

Preparation

- (1) Wear an anti-static wrist strap close to your skin and have it properly grounded.
- (2) Take out the fan module from the package.

Steps

- (1) Unloosen the captive screws on the fan module with the Phillips screwdriver.
- (2) Pull out the fan module along the slide rail slowly and put it in the anti-static bag.
- (3) Insert the fan module into the slot along the slide rail until the fan module fully seats onto the connector on the backplane.

- (4) Tighten captive screws to secure the fan module with a Phillips screwdriver.

Figure 8-4 Replacing a Fan Module

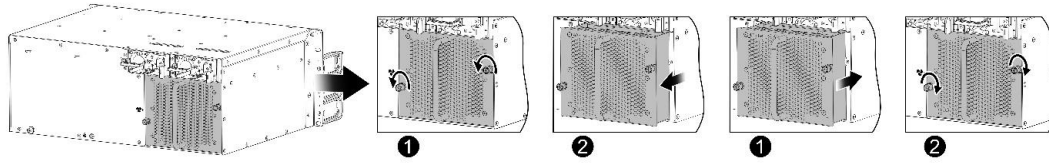

9 Cables

Note

This chapter describes the precautions and simple steps for cable connection and bundling. For details, see Cabling Recommendations

9.1 Connecting External Port Cables

Precautions

- Correctly distinguish single-mode and multi-mode fiber-optic cables and ports.
- Avoid bends of small radius at the connector.

Simple Connection Steps

- (1) Connect one end of the RJ45 connector for configuring Ethernet cables to the MGMT port of the switch and the other end to the NMS or a control terminal.
- (2) Insert the single-mode or multi-mode fiber-optic cable into the appropriate interface according to the identification on the panel of the module. Distinguish the Rx/Tx end of the fiber.
- (3) Insert the RJ45 twisted pair into the appropriate interface according to the identification on the panel of the module. Distinguish the crossover cable and straight-through cable.
- (4) Connect the cables and fiber-optic cables of each module in sequence.

9.2 Bundling the Cables

Precautions

- The power cables and other cables should be bundled in a visually pleasing way.
- When you bundle fiber-optic cables, make sure that the fiber-optic cables at the connectors have natural bends or bends of large radius.
- Do not bundle fiber-optic cables and twisted pairs too tightly, as this may press hard the fiber-optic cables and affect their service life and transmission performance.

Simple Bundling Steps

- (1) Bundle the drooping part of the fibers and twisted pairs of each module, and lead them to both sides of the chassis for convenience.
- (2) On the both sides of the chassis, fasten the fibers and twisted pairs to the cabinet cable management ring or bracket.
- (3) For the power cables, you should bundle them closely along the bottom of the chassis, in a straight line wherever possible.

10 Appendix

10.1 Connectors and Media

1000BASE-T/100BASE-TX/10BASE-T Port

The 1000BASE-T/100BASE-TX/10BASE-T is a 10/100/1000 Mbps port with auto-negotiation, which supports auto MDI/MDIX Crossover at these three rates.

The 1000BASE-T complies with IEEE 802.3ab standard, and uses up to 100 m of 100-ohm CAT5, CAT 5e or twisted pairs with higher standard. The 1000BASE-T port uses four pairs of wires for transmission, all of which must be connected. Figure 10-1 shows the connection of the twisted pairs used by the 1000BASE-T port.

Figure 10-1 Four Twisted Pairs of the 1000BASE-T

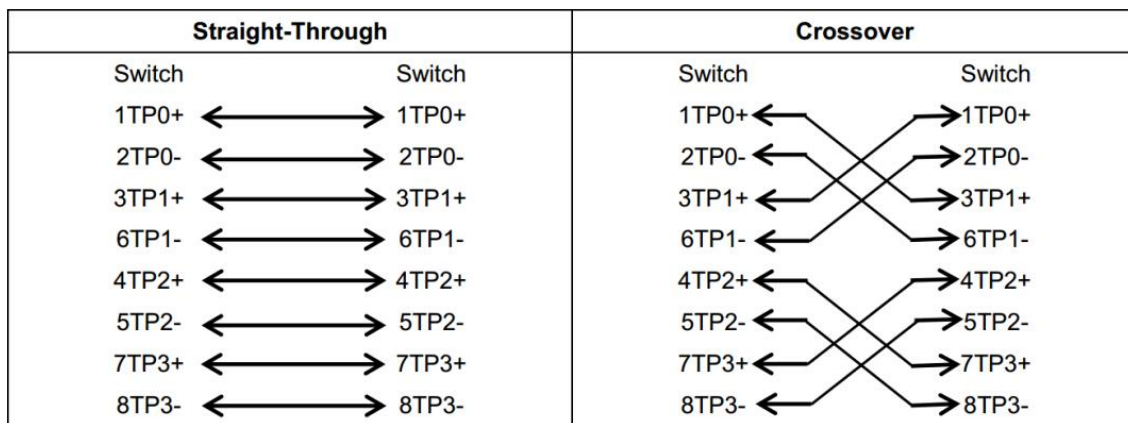

In addition to the preceding cables, the 100BASE-TX/10BASE-T can also use 100-ohm Category-3, Category-4, and Category-5 cables for 10 Mbps, and 100-ohm Category-5 cables for 100 Mbps, both of which can be up to 100 m (328.10 ft). Figure 10-2 shows the pinouts of the 100BASE-TX/10BASE-T.

Figure 10-2 Pinouts of the 100BASE-TX/10BASE-T

Pin	Socket	Plug
1	Input Receive Data+	Output Transmit Data+
2	Input Receive Data-	Output Transmit Data-
3	Output Transmit Data+	Input Receive Data+
6	Output Transmit Data-	Input Receive Data-
4,5,7,8	Not used	Not used

Figure 10-3 shows the straight-through and crossover cable connections for the 100BASE-TX/10BASE-T.

Figure 10-3 Connections of the Twisted Pairs of the 100BASE-TX/10BASE-T

Straight-Through		Crossover	
Switch	Adapter	Switch	Switch
1 IRD+	1 OTD+	1 IRD+ ←	1 IRD+ →
2 IRD-	2 OTD-	2 IRD- ←	2 IRD- →
3 OTD+	3 IRD+	3 OTD+ ←	3 OTD+ →
6 OTD-	6 IRD-	6 OTD- ←	6 OTD- →

Fiber-Optic Cable Connection

For the optical ports, select single-mode or multimode fiber-optic cables for connections according to the optical module connected. Figure 10-4 shows the connection schematic diagram.

Figure 10-4 Fiber-Optic Cable Connections

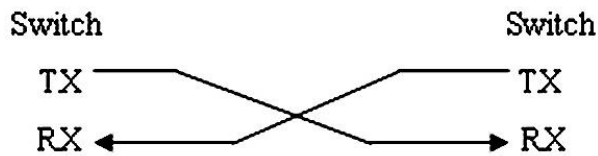

10.2 Mini-GBIC and 10GE SFP+ Modules Specifications

SFP modules (mini-GBIC module) and 10GE SFP+ modules are available to cope with interface types of switch modules. You can select the mini-GBIC module to suit your specific needs. The models and technical specifications of some mini-GBIC and 10GE SFP+ modules are listed below. For details, see *Ruijie Module Installation and Reference Guide*.

Table 10-1 Models and Technical Specifications of the 1GE Mini-GBIC (SFP) Module

Model	Wave Length (nm)	Media Type	DDM (Yes/No)	Intensity of Transmitted Light (dBm)		Intensity of Received Light (dBm)	
				Min	Max	Min	Max
MINI-GBIC-SX-MM850	850	MMF	No	-9.5	-3	-17	0
MINI-GBIC-LX-SM1310	1310	SMF	No	-9.5	-3	-20	-3
MINI-GBIC-LH40-SM1310	1310	SMF	Yes	-2	3	-22	-3
GE-SFP-LX20-SM1310-BIDI	1310TX/1550RX	SMF	Yes	-9	-3	-20	-3
GE-SFP-LX20-SM1550-BIDI	1550TX/1310RX	SMF	Yes	-9	-3	-20	-3
GE-SFP-LH40-SM1310-BIDI	1310TX/1550RX	SMF	Yes	-5	0	-24	-1
GE-SFP-LH40-SM1550-BIDI	1550TX/1310RX	SMF	Yes	-5	0	-24	-1
MINI-GBIC-ZX80-SM1550	1550	SMF	Yes	0	4.7	-22	-3
MINI-GBIC-ZX100-SM1550	1550	SMF	Yes	0	5	-30	-9
SFP-MM850	850	MMF	No	-9.5	-3	-17	0
SFP-SM1310	1310	SMF	No	-9.5	-3	-20	-3
GE-SFP-ZX	850	MMF	Yes	-9.5	-3	-17	0
GE-SX-MM850	850	MMF	Yes	-9.5	-3	-17	0
GE-LX-SM1310	1310	SMF	Yes	-9	-3	-20	-3
SFP-S4-R1000P1 v1	1310	SMF	Yes	0	5	-30	-9

Table 10-2 Models of 1GE SFP Copper Module

Standard	Model	DDM (Yes/No)
1000Base-T	Mini-GBIC-GT	No

Table 10-3 SFP Module Cabling Specification

SFP Model	Interface Type	Fiber Type	Core Size(μm)	Cabling Distance
MINI-GBIC-SX-MM850	LC	MMF	62.5/125	275 m
			50/125	550 m
MINI-GBIC-LX-SM1310	LC	SMF	9/125	10 km
MINI-GBIC-LH40-SM1310	LC	SMF	9/125	40 km
GE-SFP-SX-SM1310-BIDI	LC	MMF	50/125	500 m
GE-SFP-SX-SM1550-BIDI	LC	MMF	50/125	500 m
GE-SFP-LX20-SM1310-BIDI	LC	SMF	9/125	20 km
GE-SFP-LX20-SM1550-BIDI	LC	SMF	9/125	20 km
GE-SFP-LH40-SM1310-BIDI	LC	SMF	9/125	40 km
GE-SFP-LH40-SM1550-BIDI	LC	SMF	9/125	40 km
MINI-GBIC-ZX80-SM1550	LC	SMF	9/125	80 km
MINI-GBIC-ZX100-SM1550	LC	SMF	9/125	100 km
SFP-MM850	LC	MMF	50/125	500 m
SFP-SM1310	LC	SMF	9/125	10 km
GE-SFP-ZX	LC	MMF	50/125	550 m
GE-SX-MM850	LC	MMF	50/125	500 m
GE-LX-SM1310	LC	SMF	9/125	10 km
SFP-S4-R1000P1 v1	LC	SMF	9/125	10 km
Mini-GBIC-GT	RJ45	Category 5 (or above) UTP or STP		100 m

GE-SFP-GT	RJ45	Category 5 (or above) UTP or STP	100 m
SFP-GT	RJ45	Category 5 (or above) UTP or STP	100 m

i Note

- For the optical module with the transmission distance exceeding 40 km (24.85 miles) or above, add one in-line optical attenuator on the link to avoid the overload of the optical receiver when short single-mode fiber-optic cables are used.
- Optical modules generate laser. Do not look directly into the optical module.
- To keep optical modules clean, use dust caps when the modules are not connected to fiber-optic cables.
- No extra cables are needed when SFP cables are used. To allow two ports to communicate easily, install the two ends of a SFP cable into corresponding ports.

Table 10-4 Specifications of SFP BIDI Optical Module Pairs

Rate/Distance	Module Pairs
1000 Mbps/500 m	GE-SFP-SX-SM1310-BIDI GE-SFP-SX-SM1550-BIDI
1000 Mbps/20 km	GE-SFP-LX20-SM1310-BIDI GE-SFP-LX20-SM1550-BIDI
1000 Mbps/40 km	GE-SFP-LH40-SM1310-BIDI GE-SFP-LH40-SM1550-BIDI
10GE/10 km	XG-SFP-LR-SM1270-BIDI XG-SFP-LR-SM1330-BIDI

⚠ Caution

The BIDI modules must be used in pairs, for example, FE-SFP-LX20-SM1310-BIDI and FE-SFP-LX20-SM1550-BIDI are used together.

Table 10-5 Models and Specifications of 10GE SFP+ Modules

Model	Wavelength (nm)	DDM (Yes/No)	Fiber Type	Transmit (dBm)		Receive (dBm)	
				MIN	MAX	MIN	MAX
XG-SFP-SR-MM850	850	Yes	MMF	-7.3	-1	-9.9	-1
XG-SR-MM850	850	Yes	MMF	-7.3	-1	-9.9	-1

SFP+MM850	850	Yes	MMF	-7.3	-1	-9.9	-1
XG-SFP-LR-SM1270-BIDI	1270	No	SMF	-6.5	0.5	-14.4	0.5
XG-SFP-LR-SM1330-BIDI	1330	No	SMF	-6.5	0.5	-14.4	0.5
XG-LR-SM1310	1310	Yes	SMF	-8.2	0.5	-14.4	0.5
SFP+SM1310	1310	Yes	SMF	-8.2	0.5	-14.4	0.5
XG-SFP-LR-SM1310	1310	Yes	SMF	-8.2	0.5	-14.4	0.5
XG-eSFP-LR-SM1310	1310	Yes	SMF	-8.2	0.5	-14.4	0.5
XG-SFP-ER-SM1550	1550	Yes	SMF	-4.7	4	-11.3	-1
XG-SFP-ZR-SM1550	1550	Yes	SMF	0	4	-24	-7
SFP-S4-R1000P1 v2	1310	Yes	SMF	-8.2	0.5	-14.4	0.5
SFP-S1-R1000P1	1310	Yes	SMF	-8.2	0.5	-14.4	0.5
SFP+1310	1310	Yes	SMF	-8.2	0.5	-14.4	0.5
SFP-M3-R1000P1	850	Yes	MMF	-7.3	-1	-11.1	-1
XG-LR-SM1310	1310	Yes	SMF	-8.2	0.5	-14.4	0.5
HSFP-XG-SFP-LR-SM1310	1310	Yes	SMF	-8.2	0.5	-14.4	0.5
XG-SFP-SR-MM850-I	850	Yes	MMF	-7.3	-1	-9.9	-1
XG-SFP-LR-SM1310-I	1310	Yes	SMF	-8.2	0.5	-14.4	0.5

Table 10-6 Models and Specifications of 10GE SFP+ AOC Modules

Model	Module Type	Connector	Length(m)	Conductor diameter(AWG)	Data Rate(Gb/s)	Support DDM (Yes/No)
XG-SFP-AOC1M	Active	SFP+	1	\	10.3125	Yes
XG-SFP-AOC3M	Active	SFP+	3	\	10.3125	Yes

XG-SFP-AOC5 M	Active	SFP+	5	\	10.3125	Yes
XG-SFP-AOC10 M	Active	SFP+	10	\	10.3125	Yes

i Note

The types/models of the SFP+ modules are being updated. If more accurate models of the module are required, contact Ruijie marketing staff or technical support engineers.

The TX power of AOC cable can be displayed as "N/A".

Table 10-7 10GE SFP+ Module Cabling Specification

Model	Interface Type	Fiber Type	Core Size(μm)	Modal Bandwidth (MHz.km)	Cabling Distance
XG-SFP-SR-MM850	LC	MMF	50/125	2000(OM3)	300 m
XG-SR-MM850	LC	MMF	50/125	2000(OM3)	300 m
SFP+MM850	LC	MMF	50/125	2000(OM3)	300 m
XG-SFP-LR-SM1270-BIDI	LC	SMF	9/125	N/A	10 km
XG-SFP-LR-SM1330-BIDI	LC	SMF	9/125	N/A	10 km
XG-SFP-LR-SM1310	LC	SMF	9/125	N/A	10 km
SFP+SM1310	LC	SMF	9/125	N/A	10 km
XG-SFP-ER-SM1550	LC	SMF	9/125	N/A	40 km
XG-SFP-ZR-SM1550	LC	SMF	9/125	N/A	80 km
SFP-S4-R1000P1 v2	LC	SMF	9/125	N/A	10 km
SFP-S1-R1000P1	LC	SMF	9/125	N/A	10 km
SFP+1310	LC	SMF	9/125	N/A	10 km
SFP-M3-R1000P1	LC	MMF	50/125	2000(OM3)	300 m
XG-LR-SM1310	LC	SMF	9/125	N/A	10 km
HSFP-XG-SFP-LR-SM1310	LC	SMF	9/125	N/A	10 km
XG-SFP-SR-MM850-I	LC	MMF	50/125	2000(OM3)	300 m
XG-SFP-LR-SM1310-I	LC	SMF	9/125	N/A	10 km

10.3 Lightning Protection

Installing AC Power Arrester (lightning protection cable row)

The external lightning protection cable row must be used on the AC power port to prevent the switch from being struck by lightning when the AC power cable is introduced from the outdoor and directly connected to the power port of the switch. The lightning protection cable row is fixed on the cabinet, operating table, or the wall in the equipment room using the line buttons and screws.

Figure 10-5 Schematic Diagram for the Power Arrester

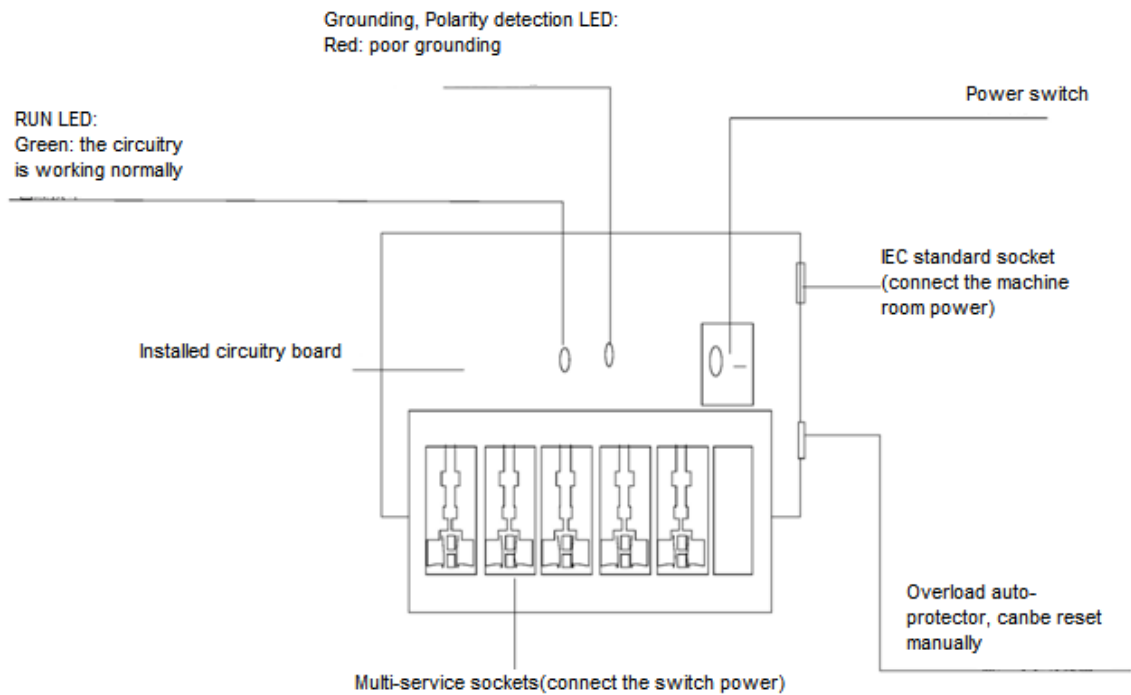

Note

The power arrester is not provided and customers have to purchase it.

Caution

Ensure that the PE terminal of the power arrester is properly grounded.

After connecting the switch AC power plug to the socket of the power arrester (lightning protection cable row), lightning protection function implements if the RUN LED is Green and the ALARM LED is OFF.

If the alarm LED on the power arrester is red, check whether there is the poor grounding connection or reversed connection of null and live lines. You can use the multimeter to check the polarity of the power socket for the arrester when the LED is red. If the N line is on the left and the L line is on the right, the arrester PE terminal is not grounded. If the L line is on the left and the N line is on the right, the polarity of the arrester power cable is reversed. If the LED is still red, the arrester PE terminal is not grounded.

Installing the Ethernet Port Arrester

During the switch usage, the Ethernet port arrester must be connected to the switch to prevent the switch damage by lightning before the outdoor network cable connects to the switch.

Tools: cross or straight screwdriver, multimeter, and diagonal pliers

Installation steps:

- (1) Tear one side of the protection paper for the double-sided adhesive tape and paste the tape to the framework of the Ethernet port arrester. Tear the other side of the protection paper for the double-sided adhesive tape and paste the Ethernet port arrester to the switch framework. The paste location for the Ethernet port arrester must be as close to the grounding terminal of the switch.
- (2) Based on the distance of the switch grounding terminal, cut the grounding line for the Ethernet port arrester and firmly tighten the grounding line to the grounding terminal of the switch.
- (3) Use the multimeter to check whether the grounding line for the arrester is in good contact with the switch grounding terminal and the framework.
- (4) According to the *Ethernet Port Arrester Hardware Installation Guide*, connect the arrester using the adapter cable (note that the external network cable is connected to the end of IN, while the adapter cable connected to the switch is connected to the end of OUT) and check whether the LED on the board is normal.
- (5) Use the nylon button to bundle the power cables.

Figure 10-6 Schematic Diagram for the Ethernet Port Arrester Installation

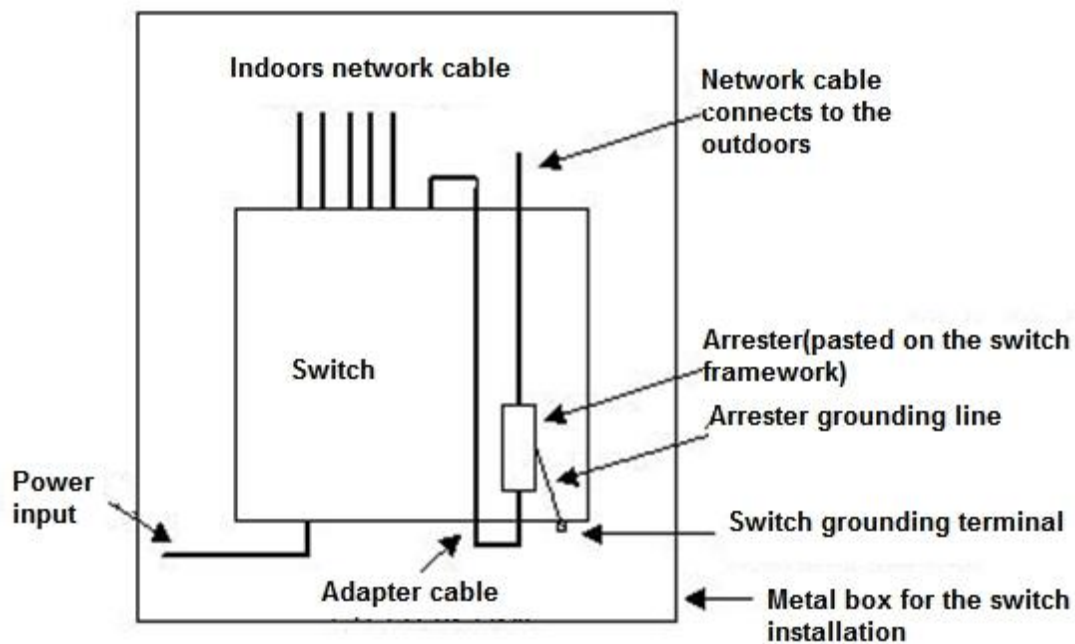

Note

The Ethernet port arrester applies to only the 10M/100M electrical Ethernet ports with the RJ45 connector.

The Ethernet port arrester is not delivered with the switch. The user can purchase one arrester as required.

The Ethernet port arrester is provided by customers. For more information about arrester installation, refer to Ethernet Port Arrester Hardware Installation Guide.

To prevent the performance of the Ethernet port arrester from being affected, note the following points:

- Reversed direction of the arrester installation: Connect the external network cable to the IN end and connect the switch Ethernet port to the OUT end.
- Poor arrester grounding: The grounding line must be as short as possible to ensure that it is in good contact with the switch grounding terminal. Use the multimeter to confirm the contact after grounding.
- Incomplete arrester installation: If more than one port is connected to the peer device on the switch, install the arresters on all connection ports for lightning protection.

10.4 Cabling Recommendations

When RG-NBS7000 series switches are installed in standard 19-inch cabinets, cables are tied in the binding rack on the cabinet by the cabling rack, and top or bottom cabling is adopted according to the actual situation in the equipment room. All cable connectors should be placed at the bottom of the cabinet in an orderly manner but not outside the cabinet. Power cables are routed beside the cabinet, and top or bottom cabling is adopted according to the actual situation in the equipment room, such as the position of the DC power distribution box, AC socket, or lightning protection box.

Requirements for the Minimum Cable Bending Radius

- The bending radius of a power cord, communication cable, and flat cable should be five times greater than their respective diameters. The bending radius of these cables that often bend or is removed or installed should be seven times greater than their respective diameters.
- The bending radius of a common coaxial cable should be seven times greater than its diameter. The bending radius of this type of cables that often bend or is removed or installed should be 10 times greater than its diameter.
- The bending radius of a high-speed cable (for example, SFP cable) should be five times greater than its diameter. The bending radius of this type of cables that often bend or is removed or installed should be 10 times greater than its diameter.

Requirements for the Minimum Fiber Bending Radius

- The diameter of a fiber tray to hold fibers cannot be 25 times less than the diameter of the fiber.
- When moving an optical fiber, the bending radius of the fiber should be equal to or 20 times greater than the diameter of the fiber.
- During cabling of an optical fiber, the bending radius of the fiber should be equal to or 10 times greater than the diameter of the fiber.

Precautions for Bundling Up Cables

- Before bundling up cables, correctly mark labels and stick the labels to cables.
- Cables should be neatly and properly bundled, as shown in Figure 10-7.

Figure 10-7 Bundling Cables (1)

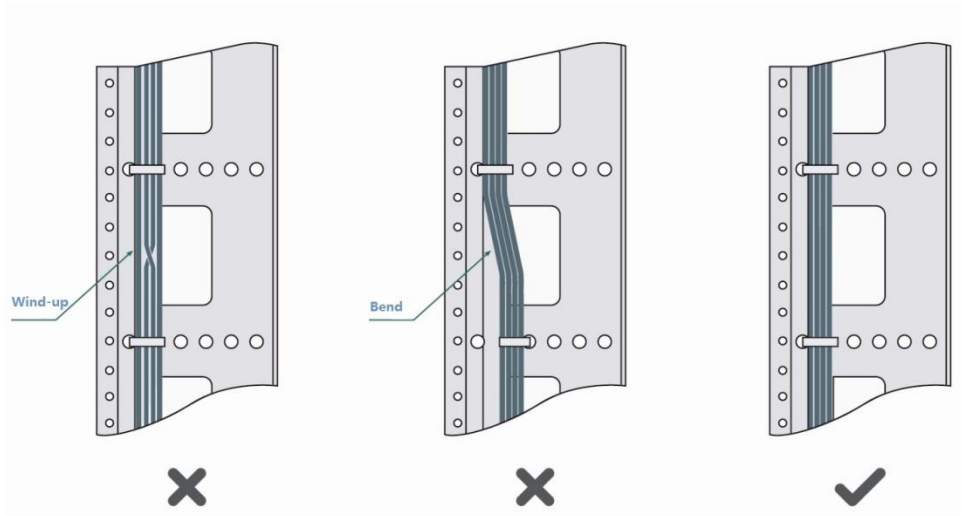

- Cables of different types (such as power cords, signal cables, and ground cables) should be separated in cabling and bundling. When they are close, crossover cabling can be adopted. In the case of parallel cabling, maintain a space of at least 30 mm (1.18 in.) for power cords and signal cables.
- The binding rack and cabling slot inside and outside the cabinet should be smooth, without sharp corners.
- The metal hole traversed by cables should have a smooth and fully rounding surface or an insulated lining.
- Proper buckles should be selected to bundle up cables. It is forbidden to connect two or more buckles to bundle up cables.
- After bundling up cables with buckles, you should cut off the remaining part. The cut should be smooth and trim, without sharp corners, as shown in Figure 10-8.

Figure 10-8 Bundling Cables (2)

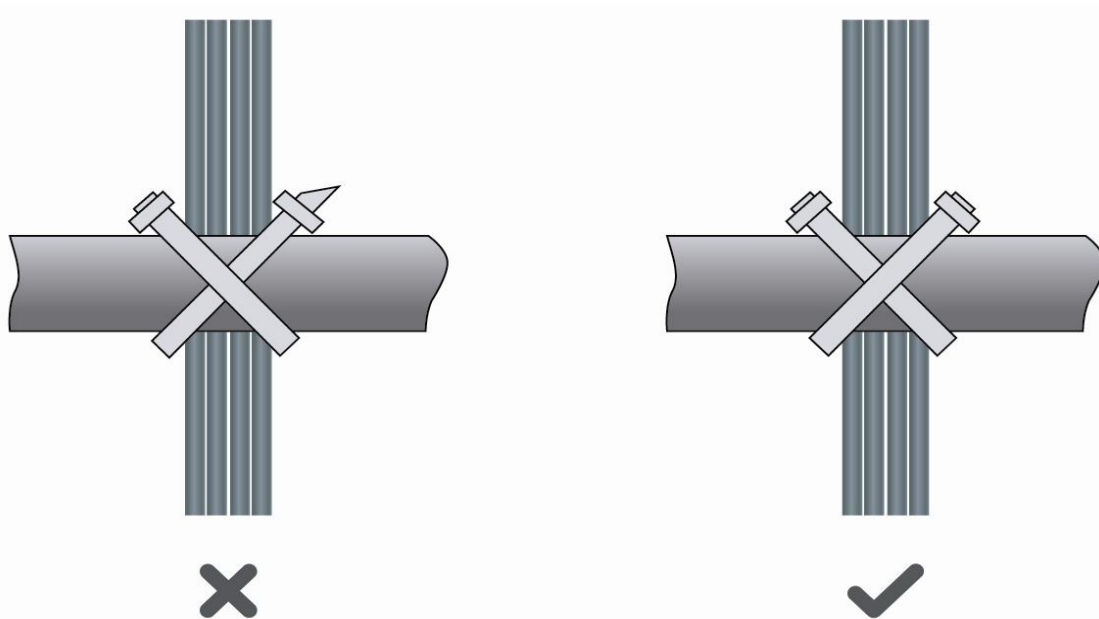

- When cables need to bend, first bundle them up. However, the buckle cannot be bundled within the bending area. Otherwise, significant stress may be generated in cables, breaking cable cores.

Figure 10-9 Bundling Cables (3)

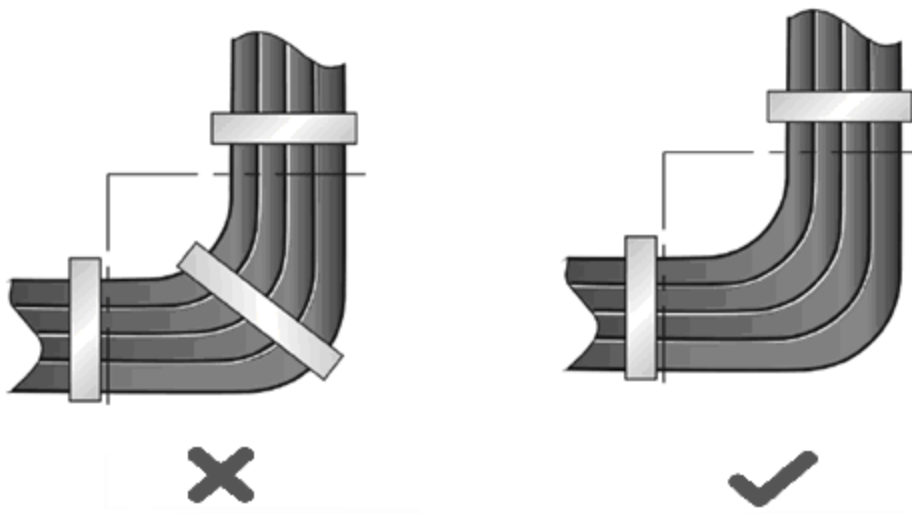

- Cables not to be assembled or remaining parts of cables should be folded and placed in a proper position of the cabinet or cabling slot. The proper position will not affect device running or cause device or cable damage during commissioning.
- Power cords cannot be bundled on guide rails of moving parts.
- Power cables connecting moving parts such as door grounding wires should be reserved for access after being assembled. When the moving part reaches the installation position, the remaining part should not touch heat sources, sharp corners, or sharp edges. If heat sources cannot be avoided, high-temperature cables should be used.
- When using screw threads to fasten cable terminals, the bolt or screw must be tightly fastened, and anti-loosening measures should be taken, as shown in Figure 10-10.

Figure 10-10 Cable Fastening

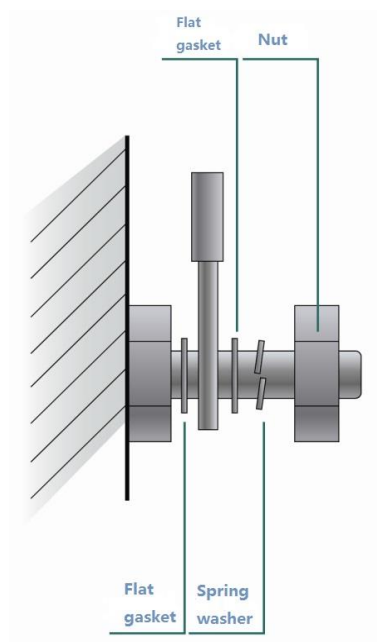

- The hard power cable should be fastened by the terminal connection area to prevent stress.

- Do not use self-tapping screws to fasten terminals.
- Power cables of the same type in the same cabling direction should be bundled up into cable bunches, with clean and straight cables in cable bunches.
- Binding by using buckles should be performed according to Table 10-8.

Table 10-8 Cable Bunch

Cable Bunch Diameter (mm)	Binding Space (mm)
10	80 to 150
10 to 30	150 to 200
30	200 to 300

- No knot is allowed in cabling or bundling.
- For solder-less terminal blocks (such as air switches) of the cold pressing terminal type, the metal part of the cold pressing terminal should not be exposed outside the terminal block during assembly.

10.5 Site Selection

- The equipment room should be at least 5 km (3.11 miles) away from the heavy pollution source such as the smelter, coal mine, and thermal power plant, 3.7 km (2.30 miles) away from the medium pollution source such as the chemical industry, rubber industry, and electroplating industry, and 2 km (1.24 miles) away from the light pollution source such as the food manufacturer and leather plant. If the pollution source is unavoidable, the equipment room should be located on the windward side of the pollution source perennially with advanced protection.
- The equipment room should be at least 3.7 km (2.30 miles) away from the sea or salt lake. Otherwise, the equipment room must be sealed, with air conditioner installed for temperature control. Saline soil cannot be used for construction. Otherwise, you should select devices with advanced protection against severe environment.
- Do not build the equipment room in the proximity of livestock farms. Otherwise, the equipment room should be located on the windward side of the pollution source perennially. The previous livestock house or fertilizer warehouse cannot be used as the equipment room.
- The equipment room should be firm enough to withstand severe weather conditions such as windstorm and heavy rain as well as away from dust. If the dust is unavoidable, keep the door and window away from the pollution source.
- The equipment room should be away from the residential area. Otherwise, the equipment room should meet the construction standard in terms of noise.
- Make sure that the air vent of the equipment room is away from the sewage pipe, septic tank, and sewage treatment tank. Keep the equipment room under positive pressure to prevent corrosive gas from entering the equipment room to corrode components and circuit boards.
- Keep the equipment room away from industrial boiler and heating boiler.
- The equipment room had better be on the second floor or above. Otherwise, the equipment room floor should be 600 mm (23.62 in.) higher than the highest flood level ever recorded.
- Make sure that there are no cracks or holes in the wall and floor. If there are cable entries in the wall or window, take proper sealing measures. Ensure that the wall is flat, wear-resistant, and dust-free, which must meet requirements of flame retarding, soundproofing, heat absorption, dust reduction, and electromagnetic shielding.
- Keep the door and the window closed to make the equipment room sealed.
- The steel door is recommended for soundproofing.
- Sulfur-containing materials are forbidden.
- Pay attention to the location of the air conditioner. Keep the air conditioner from blowing wind straight toward the device or blowing water drops from the window or air vent toward the device.